



Schedule of
Electrical Permit Fees

Effective: December 1, 2007

Issued By:

Electrical Codes & Standards
MANITOBA HYDRO
PO BOX 815
WINNIPEG, MANITOBA R3C 2P4

www.hydro.mb.ca

TABLE OF CONTENTS

Schedule 1 – Flat Rate Permit Fees – Self-Wire

RESIDENTIAL

1. Single Dwellings/Mobile Homes	4
2. Trench or Overhead Conductors	4
3. Alterations, Additions, Rec Rooms, Sun Rooms, etc.	4
4. Devices Not Over 20 Amperes	5
5. Devices Over 20 Amperes	5
6. Motors, Transformers, Refrigeration, Heating, Cooking or Similar Equipment – HP/kW/kVA/Ton	5

Schedule 2 – Flat Rate Permit Fees – Contractors

RESIDENTIAL

1. Single Dwellings/Mobile Homes	6
2. Trench or Overhead Conductors	7
3. Alterations, Additions, Rec Rooms, Sun Rooms, etc.	7
4. Devices Not Over 20 Amperes	7
5. Devices Over 20 Amperes	7
6. Motors, Transformers, Refrigeration, Heating, Cooking or Similar Equipment – HP/kW/kVA/Ton	7

Schedule 2 – Flat Rate Permit Fees – Contractors

COMMERCIAL

1. Hotels, Motels, Personal Care Homes and Dormitories	8
2. Schools	8
3. Apartment Buildings and Senior Citizens' Residences	8
4. Multi-Unit Residential Complexes	8
5. Relocatable Structures	8
6. Trench or Overhead Conductors	8
7. Temporary Services	8

Schedule 3 – Itemized Permit Fees (Low Voltage Installations)

1.Consumer Services	9
2.Distribution	9
3.Devices Not Over 20 Amperes	9
4.Devices Over 20 Amperes	9
5.Electric Signs	9
6.Lamp Standards	10
7.Mobile Home and Recreational Vehicle Parks	10
8.Motors, Transformers, Refrigeration, Heating, Cooking or Similar Equipment – HP/kW/kVA/Ton	10
9.Fuel Burning Space Heating Equipment	10
10.Fuel Dispensing Devices (Gas, Propane, Natural Gas)	10
11. Voice Data Video (VDV) and Alarm Installations	10

Schedule 4– High Voltage Installations

1.Services	11
2.Distribution	11
3.Motors and Transformers	11

Schedule 5 – General

1.Hourly Inspection Rates	12
2.Safety Inspection	12
3.Travelling Expenses	12
4.Extra Inspections	12
5.Annual Permit	12
6.Special Acceptance of Electrical Equipment	12
7.Penalty	12
8.Special Inspection Prior to the Reconnection of Existing Residential Services / Dwelling Units	12
9.Special Inspection Prior to the Reconnection of Existing Commercial Services / Installations	12
10.Plans Examination	12

SCHEDULE 1 – FLAT RATE PERMIT FEES - SELF-WIRE

RESIDENTIAL ONLY

Minimum Permit Fee (Non-Refundable)	\$80.00
1. Single Dwellings/Mobile Homes	
a) New single dwellings, 200 Amps or less:	\$280.00
b) Ready-To-Move Homes (RTM) Separate permits are required for:	
i) Wiring at the building site.	\$140.00
ii) Wiring at the permanent site.	\$140.00
c) Mobile Homes – Connection of a mobile home.	\$100.00
d) Additions and Alterations to Service, Meter Socket or Distribution Panels, Temporary Services or Reconnection of Existing Services.	\$100.00
e) Central Heating, Cooling, Air Conditioning Units and Heat Pumps	\$80.00
f) Residential Garages, or similar outbuildings:	
i) Sub-panel 100 Amps and less, including 20 devices maximum	\$80.00
ii) Sub-panel exceeding 100 Amps, including 20 devices maximum	\$120.00
iii) Devices in excess of 20, as per Items 4, 5, & 6.	
g) Hot Tubs	\$80.00
h) Swimming Pools	\$110.00
i) Extra Permit	\$80.00
2. Trench or Overhead Conductors	\$80.00
3. Alterations, Additions, Rec Rooms, Sun Rooms, etc.	
Maximum 20 devices (Heating and additional devices as per Items 4, 5, & 6)	\$80.00

4. Devices Not Over 20 Amperes

Switches, receptacles, lighting fixtures, fire alarm devices and similar equipment rated not over 20 amperes.

- i) For the first 100 units, each: **\$1.60**
- ii) For the remaining units, each: **\$1.10**

5. Devices Over 20 Amperes

Switches, receptacles, lighting fixtures and similar equipment rated over 20 amperes

- i) For the first 4 units, each device: **\$8.50**
- ii) For the remaining units, each device: **\$3.00**

6. Motors, Transformers, Refrigeration, Heating, Cooling or Similar Equipment – HP/ kW/ kVA/ Ton

Each unit, including controls on the load side of the branch circuit overcurrent device:

- i) Fractional, each unit **\$3.50**
- ii) 1, but not over 4 **\$8.50**
- iii) Larger than 4, but not over 25 **\$16.00**

NOTE: For the reconnection of existing Consumer's Services which have been disconnected for 6 months or longer or for buildings located within National Parks boundaries, SEE SCHEDULE 5

SCHEDULE 2 – FLAT RATE PERMIT FEES - CONTRACTORS

RESIDENTIAL

	REGISTERED ELECTRICAL CONTRACTOR	NON- REGISTERED CONTRACTOR
Minimum Permit Fee (Non-Refundable)	\$60.00	\$80.00
1. Single Dwellings/Mobile Homes		
a) New single dwellings, 200 Amps or less:	\$150.00	\$250.00
b) New single dwelling, over 200 Amps, not exceeding 400 Amps:	\$170.00	\$300.00
c) New single dwellings, over 400 Amps.	\$300.00	\$400.00
d) Ready-To-Move Homes (RTM) Separate permits are required for:		
i) Wiring at the building site.	\$70.00	\$140.00
ii) Wiring at the permanent site.	\$70.00	\$140.00
e) Mobile Homes – Connection of a mobile home.	\$70.00	\$100.00
f) Additions and Alterations to Service, Meter Socket or Distribution Panels, Temporary Services or Reconnection of Existing Services.	\$70.00	\$100.00
g) Central Heating, Cooling, Air Conditioning Units and Heat Pumps	\$60.00	\$80.00
h) Residential Garages, or similar outbuildings		
i) Sub-panel 100 Amps and less, including 20 devices maximum	\$60.00	\$80.00
ii) Sub-panel exceeding 100 Amps, including 20 devices maximum	\$80.00	\$100.00
iii) Devices in excess of 20, as per Items 4, 5 & 6		

	<i>REGISTERED ELECTRICAL CONTRACTOR</i>	<i>NON- REGISTERED CONTRACTOR</i>
i) Hot Tubs	\$60.00	\$80.00
j) Swimming Pools	\$60.00	\$110.00
k) Extra Permit	\$60.00	\$80.00
2. Trench or Overhead Conductors		
i) Trench or Overhead Inspection	\$60.00	\$60.00
ii) Trench Approval	\$30.00	\$50.00
3. Alterations, Additions, Rec Rooms, Sun Rooms, etc.		
Maximum 20 devices (Heating and additional devices as per Items 4, 5, & 6)	\$60.00	\$80.00
4. Devices Not Over 20 Amperes		
Switches, receptacles, lighting fixtures, fire and intrusion alarm devices and similar equipment rated not over 20 amperes:		
i) For the first 100 units, each:	\$1.60	\$1.60
ii) For the remaining units, each:	\$1.10	\$1.10
5. Devices Over 20 Amperes		
Switches, receptacles, lighting fixtures and similar equipment rated over 20 amperes		
i) For the first 4 units, each device:	\$8.50	\$8.50
ii) For the remaining units, each device:	\$2.75	\$2.75
6. Motors, Transformers, Refrigeration, Heating, Cooking or Similar Equipment		
-HP/kW/kVA/Ton		
Each unit, including controls on the load side of the branch circuit overcurrent device:		
i) Fractional, each unit	\$3.50	\$3.50
ii) 1, but not over 4	\$8.50	\$8.50
iii) Larger than 4, but not over 25	\$16.00	\$16.00

NOTE: For the reconnection of existing Consumer's Services which have been disconnected for 6 months or longer or for buildings located within National Parks boundaries, SEE SCHEDULE 5

SCHEDULE 2 – FLAT RATE PERMIT FEES - CONTRACTORS

COMMERCIAL

Minimum Permit Fee (Non-Refundable)	\$60.00
1. Hotels, Motels, Personal Care Homes and Dormitories	
a) Each unit	\$70.00
b) For areas such as lounges, recreation areas, conference rooms, kitchens, dining rooms, restaurants and other commercial premises, for each 10 m ² of the floor area based on the outside dimensions	\$8.50
2. Schools	
For each 10 m ² of useable floor area, based on the outside dimensions. (Does not include re-locatable structures.)	\$8.50
3. Apartment Buildings and Senior Citizens' Residences	
Apartment buildings and senior citizens' residences, (three or more dwelling units with shared entrances and a single consumer service):	
a) Each unit (address)	\$100.00
b) For areas such as lounges, recreation areas, conference rooms, kitchens, dining rooms, restaurants and other commercial premises, for each 10 m ² of the floor area based on the outside dimensions	\$8.50
c) For commercial premises located in the building based on applicable fees as listed in Schedule 3.	
4. Multi-Unit Residential Complexes	
For garden apartments, row housing, condominiums, and other such buildings: (Separate entrances, no shared hallway)	
a) For each unit	\$120.00
b) For commercial premises located in the building based on applicable fees as listed in Schedule 3.	
5. Relocatable Structures	
i) Wiring at the building site.	\$70.00
ii) Wiring at the permanent site.	\$70.00
6. Trench or Overhead Conductors	
i) Trench or Overhead Inspection	\$60.00
ii) Trench Approval	\$30.00
7. Temporary Services	
i) Up to 200 Amperes Single phase	\$70.00
ii) Over 200 Amperes Single phase	\$125.00
iii) 3-Phase, as per Schedule 3.	

**SCHEDULE 3 – ITEMIZED PERMIT FEES
(LOW VOLTAGE INSTALLATIONS)**

1. **Consumer Services**
 For the installation or reconnection of each service box, meter socket, metering transformer enclosure, Customer Service Termination Enclosures (C.S.T.E.'s), or similar apparatus, the fee shall be determined by the ampacity of the equipment:

i) Not over 200 amperes	\$22.00
ii) Over 200 but not over 1 000 amperes	\$40.00
iii) Over 1 000 amperes	\$80.00

2. **Distribution**
 For each panelboard, switchboard, splitter, alarm panel, control panel, enclosed switch or similar apparatus, the fee shall be determined by the ampacity of the equipment:

i) Not over 200 amperes – each unit	\$22.00
ii) Over 200 but not over 1000 amperes – each unit	\$40.00
iii) Over 1000 amperes – each unit	\$80.00

NOTE: A combination service box and panelboard shall be deemed as a separate service box and panelboard.

3. **Devices Not Over 20 Amperes**
 For switches, receptacles, lighting fixtures, fire and intrusion alarm devices and similar equipment rated not over 20 amperes:

i) For the first 100 units, each device	\$1.60
ii) For the remaining units, each device	\$1.10

***Power Smart Lighting** (for each address)

i) For the first 100 units, each device	\$1.60
ii) For the remaining units, each device	\$0.55

4. **Devices Over 20 Amperes**
 For switches, receptacles, lighting fixtures and similar equipment rated over 20 amperes:

i) For the first 4 devices, each device	\$8.50
ii) For the remaining devices, each device	\$2.75

5. **Electric Signs**

i) For the first sign	\$60.00
ii) For each additional sign on the same premises and under the same permit	\$20.00

6. Lamp Standards	For each lamp standard	\$10.00
7. Mobile Home and Recreational Vehicle Parks	For power pedestals:	
	i) First 10 units, each unit	\$16.00
	ii) Remaining units, each unit	\$8.00
8. Motors, Transformers, Refrigeration, Heating, Cooking or Similar Equipment-HP/kW/kVA/Ton*	For each unit including controls on the load side of the branch circuit overcurrent device:	
	i) Fractional each unit	\$3.50
	ii) 1, but not over 4	\$8.50
	iii) Over 4, but not over 25	\$16.00
	iv) Over 25, but not over 100	\$35.00
	v) Over 100, but not over 500	\$75.00
	vi) Over 500	\$150.00
	*NOTE: For air conditioning 1 ton = 1 kW	
9. Fuel Burning Space Heating Equipment	For fuel burning equipment:	
	i) For each unit not over 200 000 BTU	\$24.00
	ii) For each unit over 200 000 BTU	\$50.00
	iii) For each fuel fired unit heater	\$8.00
	iv) For field wired associated equipment, such as valves, pumps or dampers, the fee shall be determined by the rating of each device	
10. Fuel Dispensing Devices (Gas, Propane, Natural Gas)	For each unit	\$22.00
11. Voice/Data/Video (VDV) and Alarm Installations		
	a) For the main control panel, including up to 50 devices	\$90.00
	b) For each device in excess of 50,	\$0.80
	c) For each additional rack; including all components installed in each rack, such as; hubs, patch panels, modems, router, etc. Each	\$30.00

SCHEDULE 4 – HIGH VOLTAGE INSTALLATIONS

- | | |
|--|-----------------|
| 1. Services | |
| For each service including metering and grounding. | \$300.00 |
| 2. Distribution | |
| For each unit or cell of protective or switching equipment | \$60.00 |
| 3. Motors and Transformers | |
| For each motor, transformer and similar equipment: | |
| i) Up to 500 hp/kVA | \$90.00 |
| ii) Over 500 but not over 1 000 hp/kVA | \$180.00 |
| iii) Over 1 000 hp/kVA | \$350.00 |

SCHEDULE 5 - GENERAL

1. Hourly Inspection Rates

a) Normal Office Hours

- For the inspection of an installation where the fees in Schedules 1, 2, 3 and 4 are not applicable.

i) For the first ½ hour or part thereof the fee shall be, plus GST **\$60.00**

ii) For each additional 15 minutes, plus GST **\$25.00**

b) Outside Normal Office Hours

For inspections required after normal office hours, the fee shall be double the hourly fee for normal office hours, plus GST.

2. Safety Inspection

The fee for Safety Inspection shall be at the hourly rate plus GST.

3. Travelling Expenses

When a special trip is required (minimum 3 hours), or when the installation is not accessible by road, traveling expenses may be charged in addition to the regular inspection fees.

4. Extra Inspections

Extra inspections to facilitate construction or to re-inspect the installation, the permit fee shall be at the hourly rate, plus GST.

5. Annual Permit

The fee for an annual permit shall be at the hourly rate and based on the total hours of inspection performed over a 12 month period. The minimum permit fee for an annual permit, which is payable upon application, shall be, plus GST **\$200.00**

6. Special Acceptance of Electrical Equipment

a) Special acceptance of electrical equipment shall be charged at the hourly rate, plus GST.

b) For each special acceptance label. **\$5.00**

7. Penalty

i) When an electrical permit is not requested prior to commencement of the work, a penalty in addition to the normal permit fee, plus GST, will be levied to the Permit Applicant **\$250.00**

ii) Reinstatement of permit privileges **\$250.00**

8. Special Inspection Prior to the Reconnection of Existing Residential Services or Dwelling Units, or Residential Dwellings Located Within National Parks Boundaries,

Fee per unit shall be, plus GST **\$130.00**

9. Special Inspection Prior to the Reconnection of Commercial Services or Installations

The fee will be based on the hourly rate, plus GST

10. Plans Examination

The fee will be based on the hourly rate, plus GST

Note: GST will apply as indicated

SCHEDULE 3

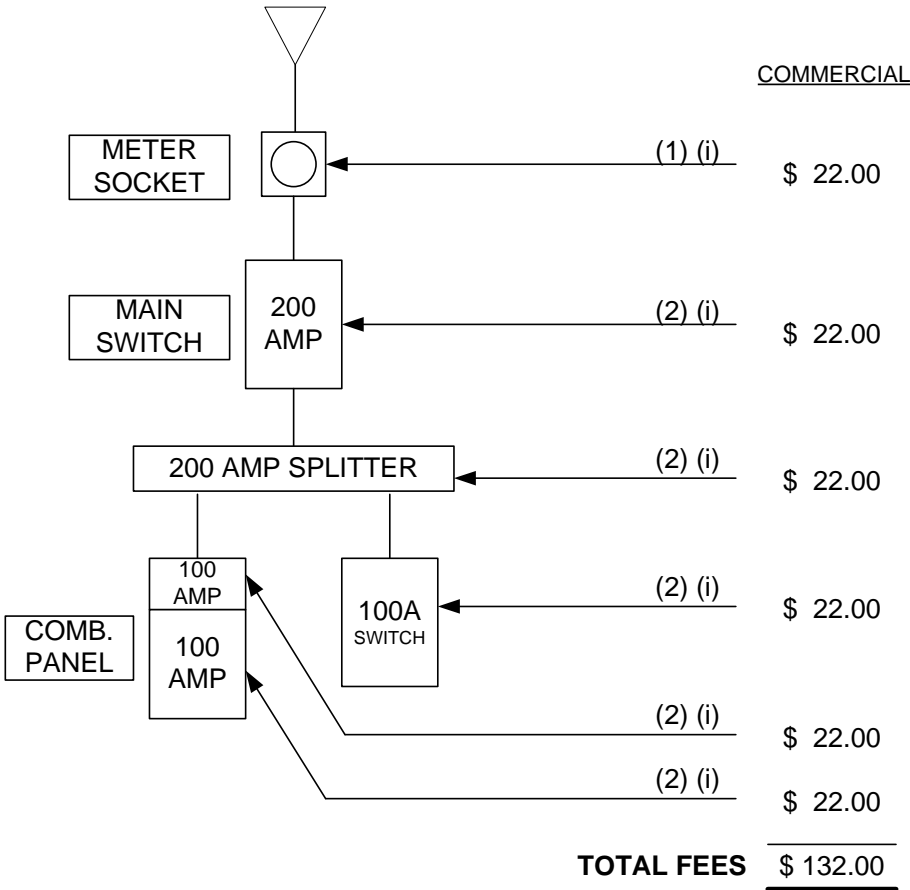
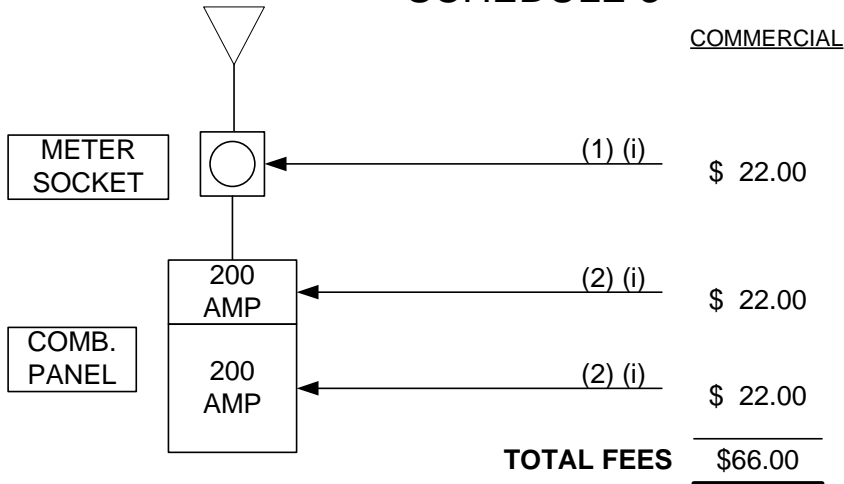

	MANITOBA HYDRO ELECTRICAL CODES & STANDARDS	
DATE: July 1, 2009	Schedule 3 COMMERCIAL PERMIT FEES Up to 200A SAMPLE CALCULATION	Drawing No. FS3 – C1

SCHEDULE 3

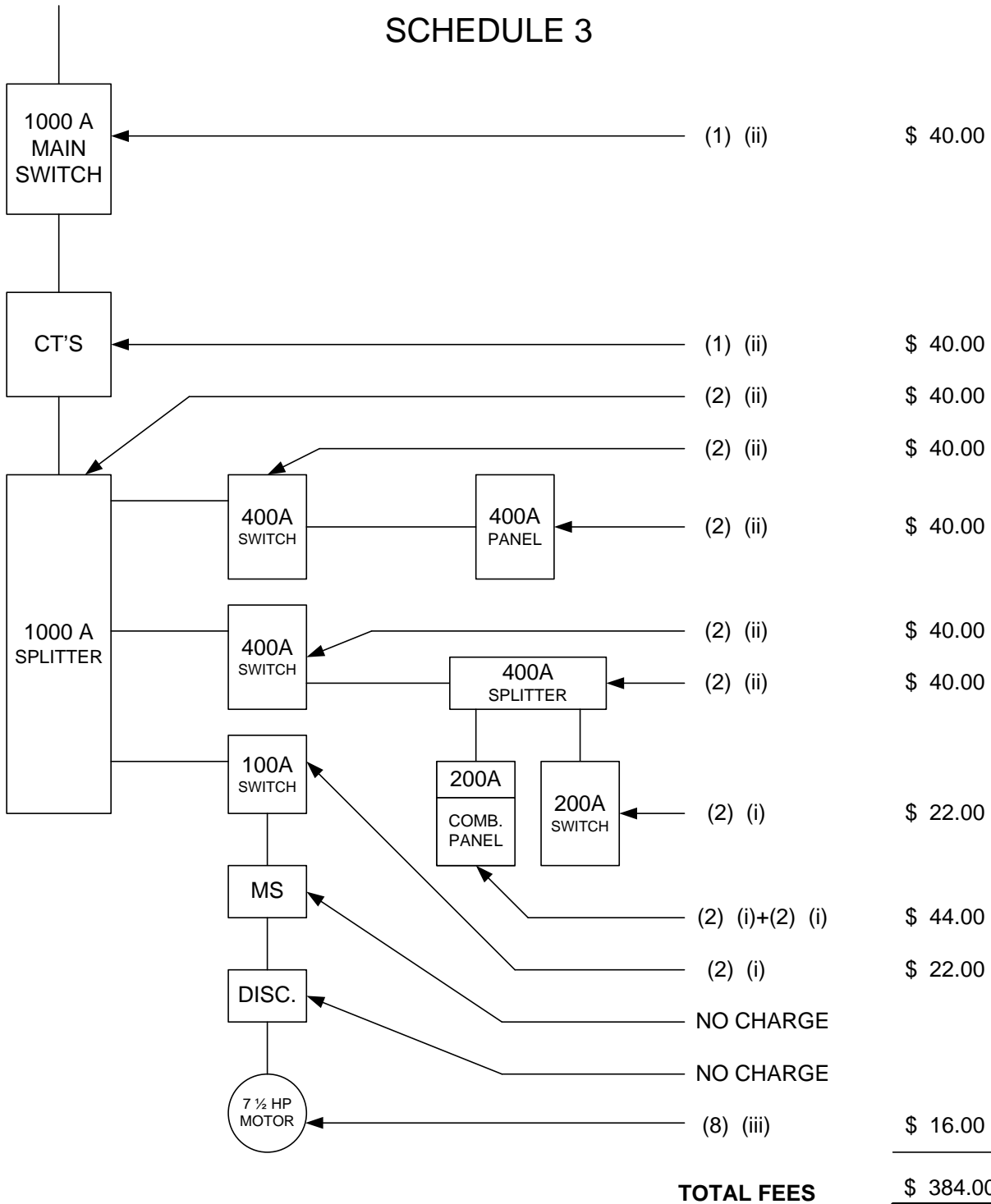

	MANITOBA HYDRO ELECTRICAL CODES & STANDARDS	
DATE: July 1, 2009	Schedule 3 COMMERCIAL PERMIT FEES OVER 200 AMP SAMPLE CALCULATION	Drawing No. FSC – C2

SCHEDULE 3

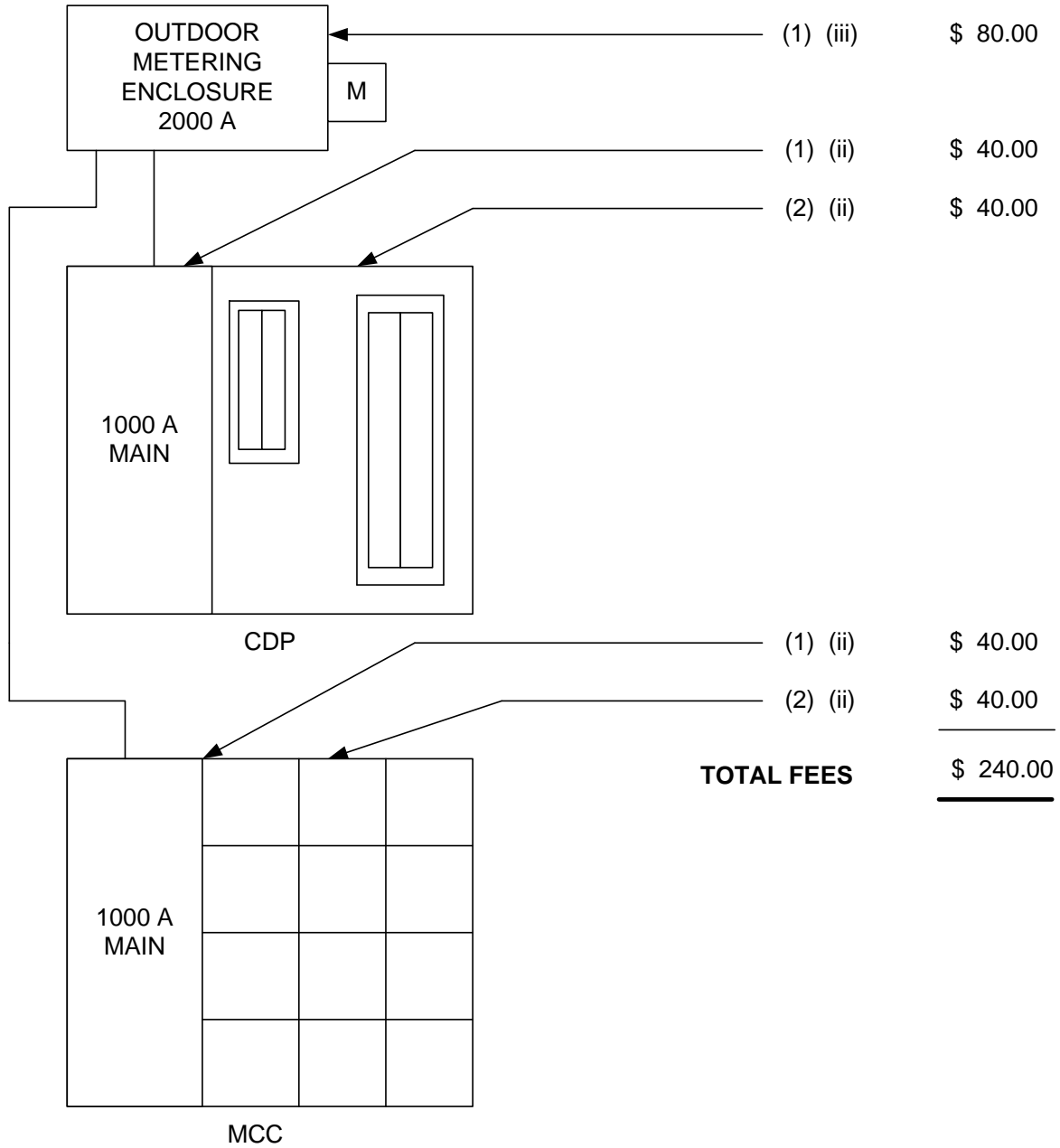

	MANITOBA HYDRO ELECTRICAL CODES & STANDARDS	
DATE: July 1, 2009	Schedule 3 COMMERCIAL PERMIT FEES OVER 1000 AMP SAMPLE CALCULATION	Drawing No. FS3-C3

SCHEDULE 4

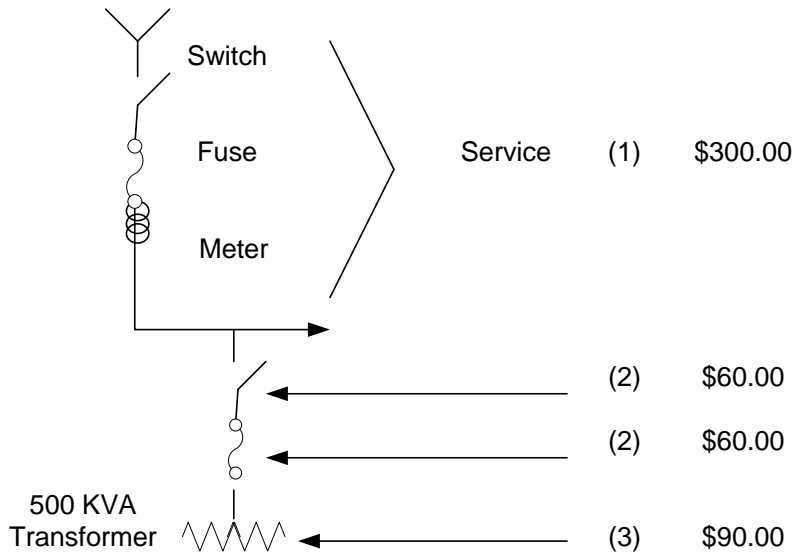

EQUIPMENT NOT INSTALLED IN SWITCHGEAR

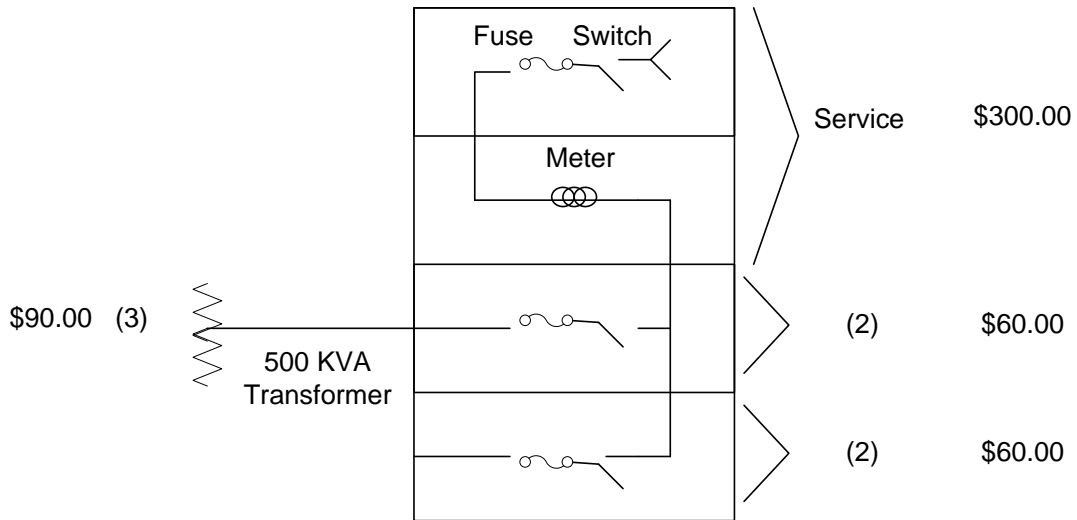

EQUIPMENT INSTALLED IN SWITCHGEAR

	MANITOBA HYDRO ELECTRICAL CODES & STANDARDS	
DATE: July 1, 2009	SCHEDULE 4 EXAMPLES OF FEES FOR HIGH VOLTAGE SAMPLE CALCULATION	Drawing No. FS4 – HV