

2

POWER SMART GUIDE:
Energy saving solutions for home comfort

Basement and crawlspace insulation



 **Manitoba
Hydro**
POWER SMART

*Manitoba Hydro is a licensee of the Trademark and Official Mark.

For more information on Power Smart:

Telephone: (204) 480-5900 in Winnipeg

Toll-Free: 1 888 MBHYDRO (1-888-624-9376)

Or visit www.hydro.mb.ca

Publications in this series

- ① Sealing, Caulking & Weatherstripping
- ② Basement & Crawlspace Insulation
- ③ Attic Insulation
- ④ Wall Insulation
- ⑤ Doors & Windows
- ⑥ Heating Systems
- ⑦ Water Heaters
- ⑧ Indoor Air Quality & Ventilation
- ⑨ Low Cost No Cost Energy Savings Tips



A large, light blue outline of the number '2' is positioned on the left side of the page. The text 'BOOKLET #2' is placed inside the upper curve of the number.

BOOKLET #2

Basement & Crawlspace Insulation

Contents

Introduction

Why Retrofit?	1
Do-it-yourself or Hire A Contractor	2

Basement Walls

Which Approach: Outside or Inside?	3
• Insulating Outside	3
• Insulating Inside	4
Precautions Before and During the Job	4
How to Insulate Basement Walls from the Outside	
• Tools Required	5
• Preparing the Walls	6
• Insulation: Which Type?	8
• Applying the Insulation	9
• Insulation Protection	10
• Backfilling	13
• Special Details	13
How to Insulate Basement Walls from the Inside	
• Tools Required	18
• Sealing the Walls	19
• Applying the Moisture Barrier	19
• Framing the Walls	21
• Special Details	23
• Insulating the Walls	25
• Applying the Air-Vapour Barrier	25
• Inside Insulation Without Framing	28
Basement Floors	
• Does It Pay To Insulate?	28

Crawlspaces

Which Approach: Heated or Unheated?	29
• Heated Crawlspace; Insulating Outside	31
• Heated Crawlspace; Insulating Inside	32
• Unheated Crawlspace	32

Introduction

Why Retrofit?

Save Money — Heating a home, especially in our climate, can be expensive. An inadequately insulated basement or crawlspace is a major source of heat loss. Concrete or stone basement and crawlspace walls and the soil that surrounds them offer little resistance to heat loss. Fortunately, this heat loss (and your energy bills) can be significantly reduced by retrofitting.

Increase Comfort — A well insulated house is a comfortable house! By retrofitting your basement, you can add to the liveable area of your home at a modest cost.

Conserve Energy — Approximately 13% of Manitoba's annual energy use goes to heat our homes. Much of that energy can and should be saved. Retrofitting your home will help save our valuable energy resources at a cost lower than producing new energy supplies.

In addition to these major benefits, retrofitting can often improve the appearance, longevity and safety of your home.

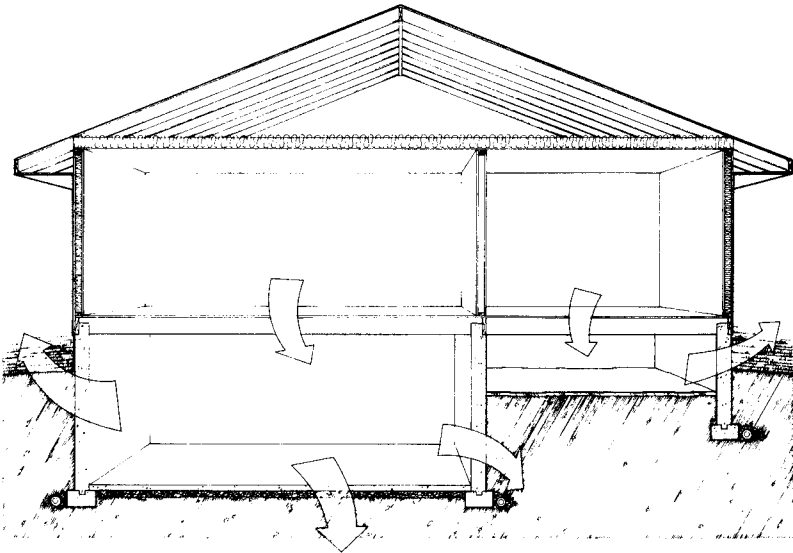

Do-It-Yourself or Hire a Contractor

This booklet has been designed to meet the needs of both the experienced and the inexperienced “do-it-yourselfer”. Most of the work described can be done by a homeowner with common household tools. By doing it yourself, both the savings and job satisfaction can be high. Please read this booklet carefully. For additional information, please contact us (see inside front cover) or your local building material supplier.

If you intend to have a contractor do some or all of the work, this booklet will still be of interest to you. You are likely to get the results you want if you are knowledgeable about the work and take an active interest in what the contractor does. For further information on how to hire a contractor, call the Consumer’s Bureau at 945-3800 (Winnipeg), toll-free at 1-800-782-0067 or email consumersbureau@gov.mb.ca.

Whether you do-it-yourself or hire a contractor, please remember that this booklet does not describe every possible technique for insulating a basement or crawlspace. *Each home is unique, and you or your contractor may find it necessary or desirable to deviate from the techniques shown in this booklet.*

Basements

Which Approach: Outside or Inside?

Basement walls can be insulated from either the outside or inside. You should carefully compare the advantages and disadvantages of each method and choose the one most suitable to your situation.

Insulating Outside

This method involves attaching a layer of insulation to the outside of the basement wall. Flashing is installed to prevent water from running down behind the insulation. Insulation exposed above-grade level is covered to provide a finished appearance and to guard against damage.

Advantages and disadvantages for this method include:

ADVANTAGES

- Previous interior work (shelves, plumbing lines, finished rooms etc.) isn't disturbed.
- If the basement is damp or leaky, the walls can be waterproofed and drain tiles installed or repaired at the same time as the insulation is installed.
- Since the basement walls are on the warm side of the insulation in winter, stresses on the wall from freeze-thaw cycles are eliminated.
- The possibility of foundation damage is minimized because frost is less likely to penetrate under the footings and the soil can't freeze directly to the basement wall.
- No loss of interior living space.

DISADVANTAGES

- Extensive excavation work is required.
- Existing landscaping is disturbed.
- Only practical to do during the warmer months.
- Existing driveways, sidewalks, porches, lot lines, etc. may make it difficult or impossible to excavate.
- Expensive to achieve high insulation values.
- May detract from the appearance of some homes.

Insulating Inside

This method typically involves installing a wood frame wall inside the basement walls. Insulation is added to the frame wall and then covered by a continuous air-vapour barrier.

Advantages and disadvantages for this method include:

ADVANTAGES

- Cost is relatively low, especially if you are finishing your basement anyway.
- Can be done any time of the year and in any weather.
- Existing landscaping doesn't have to be disturbed.
- Can economically accommodate high insulation levels.

DISADVANTAGES

- Interior finishing may already be completed.
- Obstacles such as electrical panels, wiring, plumbing, stairs and so on can make it difficult to insulate.
- Should not be used in a basement with a severe moisture problem.
- Increased potential for foundation movement if the basement is shallow or built on frost-sensitive soil.
- Hard to seal the air-vapour barrier in the floor joist header area.
- Interior living space is diminished.

Precautions Before and During the Job

After you have selected a method for insulating your basement walls, check with your local building authority to obtain any necessary building or development permits. (Winnipeg residents should call the City of Winnipeg at 986-5140; residents outside Winnipeg should call their local municipal office).

If you are going to excavate around the outside of your basement, you must establish the location and depth of any services that enter your home underground (gas, hydro, telephone, water, cable TV). Most utility companies will locate your home's underground services free of charge.

Insulating your home's basement should not pose a risk to your health or safety if proper precautions are taken. However, many insulation materials are potentially hazardous and must be handled and installed with care.

If you plan to insulate with glass fibre insulation, wear proper clothing and equipment since this type of insulation can easily irritate the skin. Long sleeves, tight cuffs, gloves and loose, thick clothing will help minimize any skin irritations. Goggles should be worn whenever there is any possibility of insulation dust coming in contact with the eyes. A hard hat can be worn to keep insulation particles out of your hair and to prevent head injuries. Always wear a breathing mask when working with insulation.

When cleaning up fibres or dust, use a vacuum cleaner. If you can only sweep-up the material, it should first be wetted to prevent particles from becoming airborne. Work clothes should be vacuumed and then washed separately from other clothing.

When insulating, you should also avoid creating a fire hazard. Most rigid insulations are very flammable and should be kept well away from the furnace or other sources of heat. If used indoors, cover any exposed rigid insulation with 13 mm (1/2-inch) drywall or equivalent. In exterior basement applications, rigid insulation exposed above the ground should be covered with stucco or pressure-treated plywood. Finally, kraft paper facing on insulation batts and polyethylene air-vapour barriers are also fire hazards, and should not be left exposed.

How to Insulate Basement Walls from the Outside

Tools Required:

- Shovels, pick and wheelbarrow for the excavation work.
- Scraper and stiff brush for cleaning the outside of the exposed basement wall.
- Basic carpentry tools (hammer, level, measuring tape, wrecking bar, caulking gun).
- Utility knife and metal straightedge for cutting the rigid insulation.
- Drill and concrete bit for drilling holes for the insulation fasteners.
- Circular saw and stone blade for cutting stucco, if required.
- Safety equipment (goggles, gloves, hard hat, mask).



Figure 1

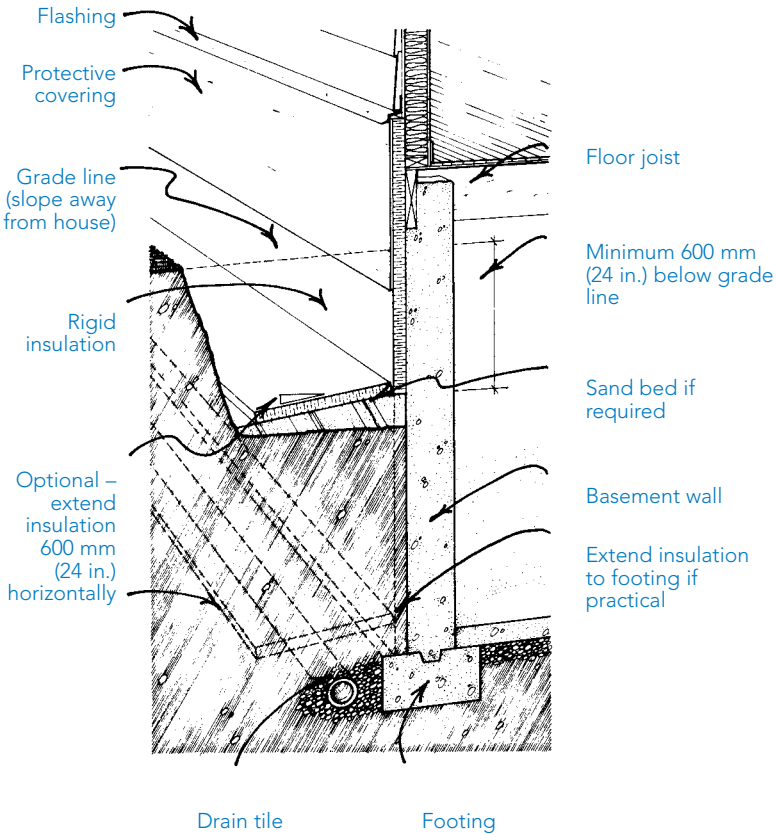

Preparing the Walls

1. The first step is to dig a trench around the foundation wall. The size of this trench will depend on how far down you intend to extend the insulation.

If the basement walls and drain tiles around the footing do not require repair, it is easiest to extend the insulation a minimum of 600mm (24 in.) below grade and then horizontally and downward (slope approximately 1 unit vertically to 5 units horizontally) for 600 mm (24 in.). This method will minimize the amount of excavation you must do (see **Figure 1**).

If the basement is damp and leaks water, it is necessary to excavate down to the bottom of the basement walls so they can be thoroughly waterproofed and the drain tile repaired or replaced. In this case, the insulation is placed vertically for the full depth of the basement walls. To further protect the soil around the drain tile and footing from freezing, the insulation can be extended horizontally at the footing level for a minimum of 600 mm (24 in.).

Digging the trench is a big job; don't make it bigger by oversizing the hole. You may even want to have it done by a contractor with the appropriate machinery. If you dig to the bottom of the basement wall, extra precautions are necessary. *The trench should be braced where required to prevent cave-ins. When not working on the trench, cover it to prevent children from falling in or rain from flooding it. Do not undermine the basement walls by digging lower than the bottom of the footing.*

2. After digging the trench, make any necessary repairs to the basement walls and drain tiles.

Cracks in the basement walls should be patched from the outside and waterproofing applied where it is cracked or missing. Damaged or missing drain tile should be replaced and then covered by granular fill.

If your house has a stone and mortar foundation, it may be necessary to apply a cement parging coat to the face of the basement wall to provide an even surface for the insulation. This parging must be applied *before* waterproofing the wall.

Since each situation is unique, it is advisable to get expert advice from your building material supplier or a contractor who is experienced in foundation repairs.

3. The last step in preparing the walls is to remove the lower portion of the siding or stucco and wall sheathing approximately 100 mm to 150 mm (4 to 6 in.) above the subfloor (see **Figure 2**). This will permit the insulation to completely cover the floor joist space.

Bottom siding pieces can be removed with a hammer and wrecking bar. Stucco can be cut with a chisel and wirecutters or a heavy duty circular saw equipped with a stone blade (these are available from tool rental agencies.).

When cutting stucco, remember to wear adequate eye and hand protection as well as a dust mask. Cut only as deep as the underlying wood or fibre board sheathing and remove the stucco by pulling out the nails or staples holding the stucco and wire in place.

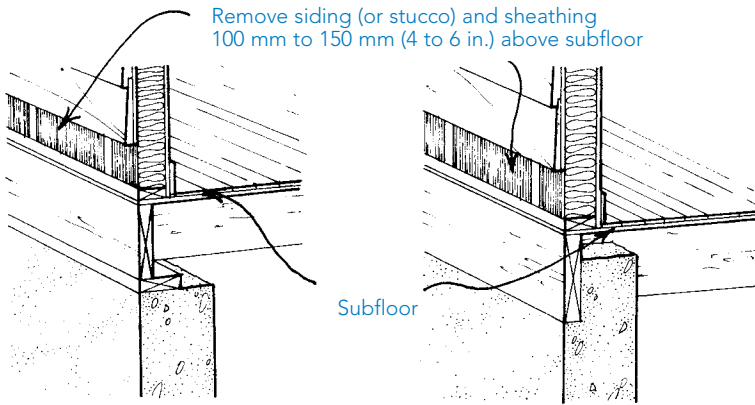

Figure 2

After removing the necessary siding or stucco, cut through the exposed sheathing with a circular saw. Remove the sheathing with a hammer and wrecking bar.

Carefully pull the last remaining piece of siding (or stucco) and building paper a few millimeters away from the wall so that flashing can be installed beneath it. (see **Figure 4** on page 11).

It may not be possible to remove the siding or stucco and wall sheathing above the level of the subfloor. If not, start the outside insulation as high as possible. The remaining uninsulated portion (usually the floor joist space) can be insulated and sealed as described on page 15.

Insulation: Which Type?

There are 3 types of insulation commonly used on the exterior of basement and crawlspace walls:

- Extruded Polystyrene
- High Density Expanded Polystyrene
- Glass Fibre Boards

All 3 types are lightweight, easy to handle and have high insulating values per unit of thickness. Both types of polystyrene can be a fire hazard if not properly covered and must also be protected from most solvents and prolonged exposure to sunlight.

Be careful not to confuse extruded or high density expanded polystyrene insulation with low density expanded polystyrene. This low density material should not be used below ground since it absorbs water over a period of time causing it to lose its effectiveness as an insulation.

Glass fibre boards are resistant to fire and can compensate for minor wall irregularities because of their flexibility. More importantly, the outer fibres of these boards provide a drainage layer to direct soil moisture down, and away from the basement and crawlspace walls. This material is more compressible than the polystyrene insulations and is a skin irritant.

In most cases, the choice of insulation will depend on availability and price.

Applying the Insulation

Before applying the insulation to the outside of the basement walls, ensure that any recently applied waterproofing is well cured.

The insulation boards can be trimmed to size by scoring and snapping or cutting directly through them with an ordinary hand saw or utility knife. Be sure to butt the boards tightly together in close contact with the wall.

Rigid insulation boards are typically 2400 mm (96 in.) long and either 600 mm (24 in.) or 1200 mm (48 in.) wide. If you are using either type of polystyrene insulation, the boards can be applied either vertically or horizontally. However, if you use glass fibre boards, they must only be applied vertically. This is because the outer layers of fibres are oriented vertically to act as a drainage layer for water.

The thickness of insulation to apply will depend on the type you choose and availability. Both types of polystyrene come in a variety of thicknesses. However, 50 mm (2 in.) and 65 mm (2 1/2 in.) are most commonly used for exterior basement wall insulation since they are widely available, easy to apply and reasonably cost-effective. These thicknesses have an insulating value of approximately RSI-1.8 (R-10) to RSI-2.2 (R-12.5). If you choose glass fibre boards, they are available in two thicknesses, 50 mm (2 in.) and 75 mm (3 in.). They have an insulating value of RSI-1.5 (R-8.5) and RSI-2.3 (R-13) respectively.

There are a number of methods for attaching the insulation to the outside of the basement wall. Although it is possible to use insulation adhesive, this method is not recommended because of the difficulty in obtaining a strong, long-lasting bond between the insulation and wall.

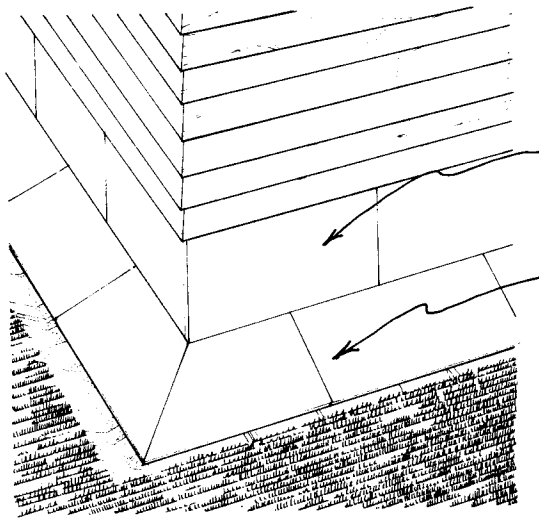

Figure 3

Vertical wall insulation

Horizontal insulation (slope away from house)

The preferred method is to use a special insulation fastener. These fasteners usually consist of a hot-dipped galvanized nail with a large washer to hold the insulation. If the fastener is to be driven into concrete or stone rather than wood, you will probably have to pre-drill a small guidance hole or use a power-activated tool. Check with your building material supplier for advice.

If the insulation is to extend horizontally out from the basement wall to further reduce heat loss (see **Figure 1** on page 6), place it on a thin bed of sand if the bottom of the excavation is not uniform. The horizontal insulation should slope away from the basement wall at a ratio of approximately 1 unit vertically to 5 units horizontally to direct run-off water away from the basement. A width of at least 600 mm (24 in.) is recommended. **Figure 3** shows how the corners can be cut to provide full coverage.

Insulation Protection

1. The first step in protecting the insulation is to apply *flashing* to prevent run-off water from getting in behind the insulation. As shown in **Figure 4** (on page 11), the flashing extends from under the siding (or stucco) and building paper over top of the insulation boards to direct water away from the joint.

The size of the flashing will depend on the thickness of your insulation layer. It can be custom made by a sheet metal fabricator from galvanized metal or aluminum. Once installed, it can either be left unpainted or colored to match existing siding or trim.

Figure 4

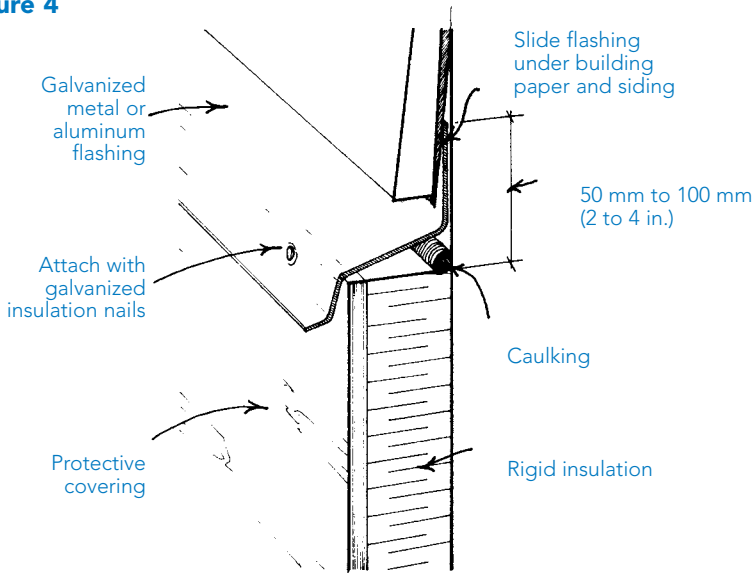

Although each situation is unique, it is often easiest to slide the flashing into place under the existing siding (or stucco) and building paper *before* the wall insulation is installed. After the insulation and protective covering is in place, the flashing can be lowered slightly and secured with hot-dipped galvanized nails.

2. The next step in protecting the insulation is to apply a protective covering on the portion that will be exposed above the grade line. This is necessary to provide a finished appearance and to prevent damage to the insulation from physical contact. In addition, polystyrene insulation must be covered to prevent degradation from sunlight. A number of materials can provide this protective covering. The most common include latex-based foundation coating, stucco over wire lath and pressure-treated plywood.

Latex-based foundation coating consists of a dry powder which is mixed with a special liquid additive. Prior to applying the coating, a self-sticking fiberglass tape is applied to all joints between insulation panels, to all outside corners and over all fastener heads and damaged insulation areas. After this, a 3 mm (1/8 in.) coating is applied over the insulation and then textured with a brush. After the coating has cured, it may be painted with exterior latex paint or simply left its natural gray color. This type of foundation coating is usually sold as a kit which includes the dry powder, liquid additive,

Figure 5

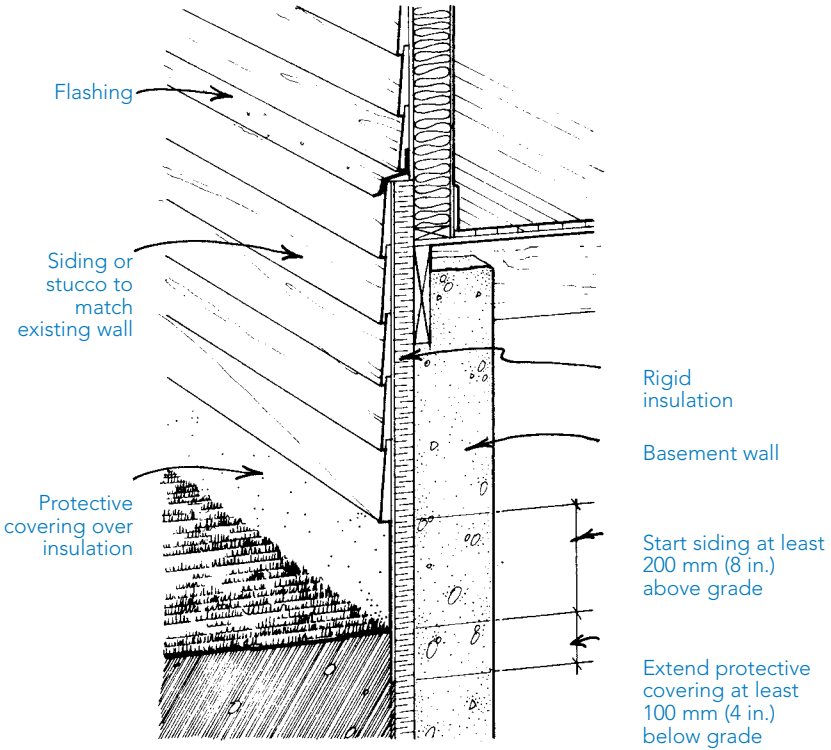

fiberglass tape, brush and mixing pail. It is only suitable for application to polystyrene insulation and should extend about 100 mm (4 in.) below grade to accommodate possible settlement of the soil after backfilling.

Another alternative is to cover the insulation with stucco. When applying stucco wire over “soft” surfaces such as glass fibre boards or polystyrene, make sure the wire is not embedded too deeply into the surface. The wire must stand out from the surface to enable the stucco to bond to it. *Wear hand and eye protection when working with stucco wire.* Mixing and applying the stucco in a consistent manner is difficult for many homeowners; you may want to hire a contractor for this portion of the work.

Yet another alternative is to cover the insulation with pressure-treated plywood. The plywood can be held in place using insulation fasteners. The cut edge of the plywood sheets should be placed above the grade line (where possible). Cut edges placed below the grade should be brushed with preservative.

If your home's foundation is well above the grade line, you can disguise the insulation by using siding or stucco that matches your home (see **Figure 5** on page 12). Less expensive, regular exterior grade plywood can be substituted for treated plywood for areas more than 300 mm (8 in.) above grade. Exposed pressure-treated plywood can be painted to provide a finished appearance.

Backfilling

After installing the insulation, flashing and protective covering, backfill and compact your excavation carefully a few centimetres at a time. Avoid using large stones, lumps of clay or other debris as these types of materials could damage the insulation. The final grade line should slope away from the basement walls to reduce the potential for water seepage into the basement (see **Figure 1** on page 6). Eavestroughs should be properly installed and downspouts extended as far as practical away from the basement.

The final grade line may be covered with most types of surfaces — grass, patio stones, or a garden. Shrubbery with deep roots should be avoided. If soil settlement occurs in later years, add fill to maintain the slope away from the basement walls.

Special Details

1. **Reduce Air Leakage** — There can be a significant amount of heat loss due to air leakage at the junction of the floor joist system and basement wall. **Figure 6** (on page 14) shows how to seal typical air leakage paths for three common types of floor joist/basement wall junctions (this sealing is only required for cases where the floor joists are not to be insulated from the inside).

Gaps around wires, pipes, and ducts that penetrate the wall should be caulked. For hard-to-reach spots, plastic tubing can be used to extend the nozzle of a tube of caulk. If the gap is large, you may have to use backing (eg. oakum, ethafoam rod, sponge rubber) for the caulking, as shown in **Figure 7** (on page 15).

Expanding polyurethane foam from an aerosol can may also be used to seal large gaps and cracks. This foam is flammable and should be covered if left exposed.

Figure 6

A) Floor joists on sill plate

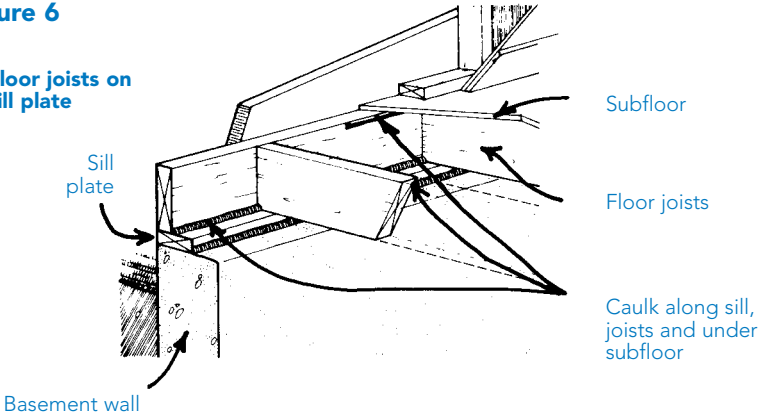

B) Floor joists partially cast-in

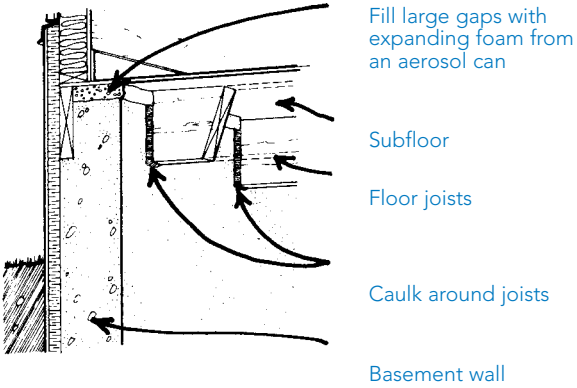

C) Floor joists fully cast-in

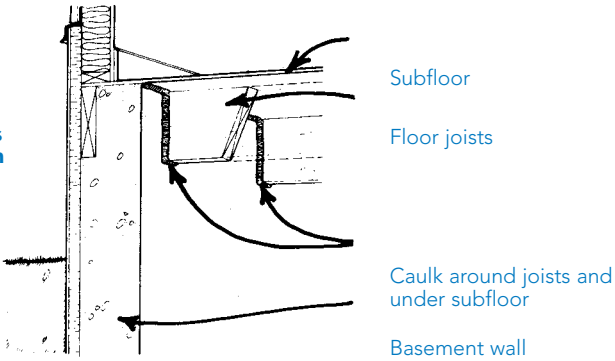
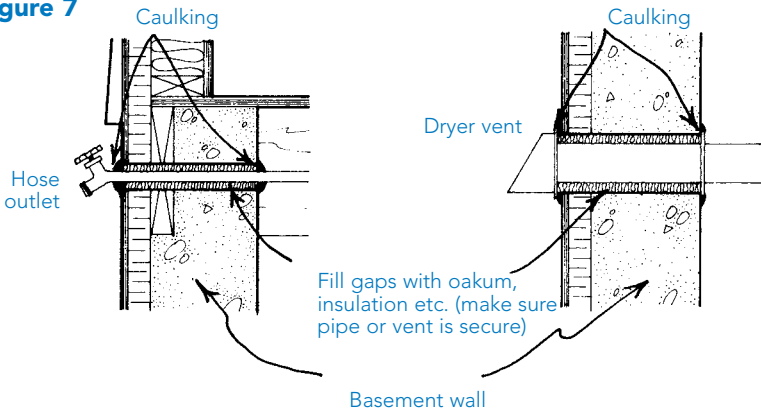

Figure 7



DO NOT attempt to seal the main electrical service where it enters your house. This requires special techniques and is too dangerous for most homeowners to attempt.

Use good quality, durable caulking materials that are compatible with concrete and other materials you seal. Another publication in this series, *Sealing, Caulking and Weatherstripping* (Booklet #1) contains more information about caulking materials and how to apply them.

2. **Insulating the Joist Space** — With some homes, it may be impossible to extend the exterior basement wall insulation to cover the floor joist space. This may be the case, for example, if your home has brick facing. This creates an uninsulated gap which must be insulated from the inside.

Figure 8 (on page 18) shows how to seal and insulate three common types of floor joist/basement wall junctions. Note that if the floor joists are fully cast-in the basement walls, use a maximum of 25 mm (1 in.) of rigid insulation between the floor joists. If more insulation is used, the concrete between the floor joists will become much cooler, possibly making the floor above uncomfortably cool.

If there are accessible floor overhangs in your home as there are in many bi-level homes or under bow and bay windows, make sure that these areas are fully insulated and well sealed as shown in **Figure 9** (on page 17). (You may have to remove the soffit under the overhang to gain access.)

Figure 8

A) Floor joists on sill plate

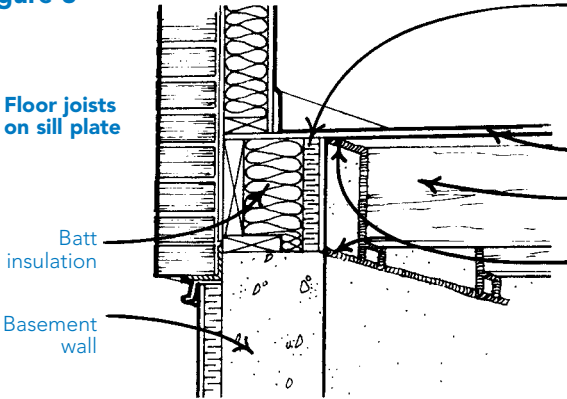

- Rigid insulation
- 25 mm (1 in.) thick
- cut to fit tightly
- cover with drywall

Subfloor

Floor joist

Caulk around joists, along top of wall and under subfloor

B) Floor joists partially cast-in

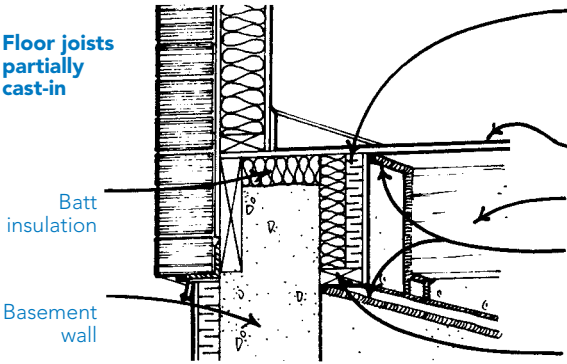

- Rigid insulation
- 25 mm (1 in.) thick
- cut to fit tightly
- cover with drywall

Subfloor

Floor joist

Caulk around joists, along top of wall and under subfloor

38 x 89 mm (2 x 4 in.)
Blocking

C) Floor joists fully cast-in

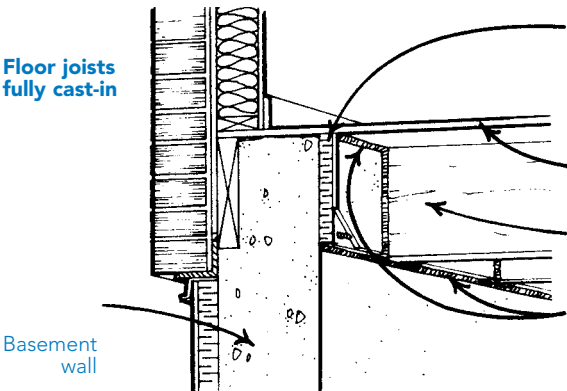

- Rigid insulation
- 25 mm (1 in.) thick
- cut to fit tightly
- cover with drywall

Subfloor

Floor joist

Caulk around joists, along top of wall and under subfloor

Figure 9

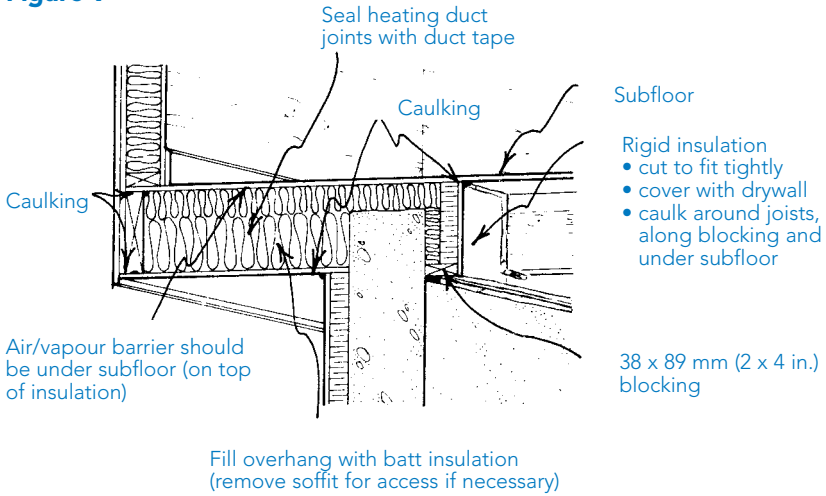

An alternative is to hire a contractor to blow insulation in through holes drilled in the underside of the overhang or to apply rigid insulation to the underside of the overhang.

3. **Insulating Around Obstructions** — **Figure 10** shows how to insulate around basement windows. The protective covering you have applied to the insulation should also be used around the window opening. Flashing should be used to extend the window sill over the insulation.

Figure 10

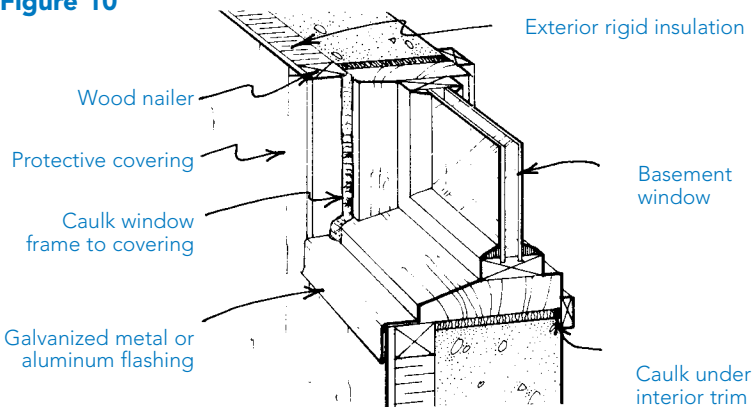
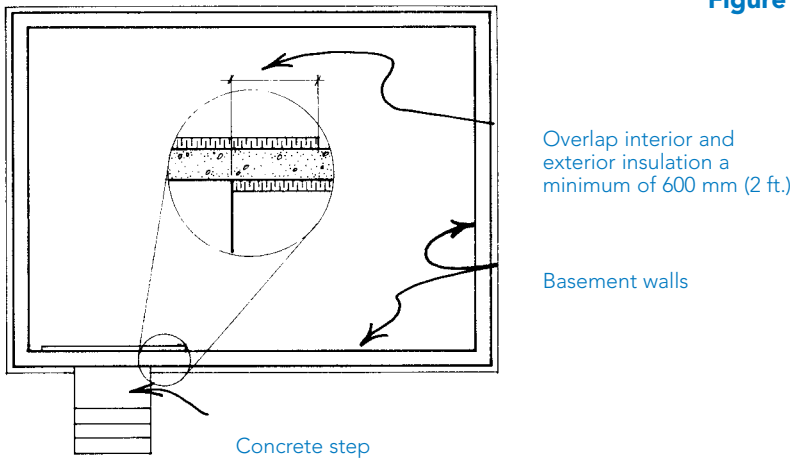

Figure 11



Some areas of your home's basement walls may be impossible to insulate from the outside due to driveways, sidewalks, steps, and so on. Insulating portions of the wall on the inside is one solution to these uninsulated areas. Be sure to overlap the interior and exterior insulation at least 600 mm (24 in.) to minimize heat loss, as shows in **Figure 11**. For detailed information on how to insulate on the interior of basement walls, refer to page 18 to 28.

How to Insulate Basement Walls from the Inside

Tools Required:

- Basic carpentry tools (hammer, level, measuring tape, carpenter's square, caulking gun, stapler, saw).
- Utility knife and metal straightedge for cutting the insulation, polyethylene air-vapour barrier and moisture barrier.
- Drill and concrete bit.
- Safety equipment (goggles, gloves, hard hat, mask).

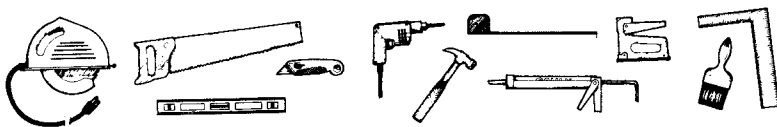

Sealing the Walls

Before you begin, inspect the basement walls for possible moisture problems. Occasional minor dampness on the walls (especially in late spring or early summer) is permissible as long as the correct procedures are followed when installing the insulation.

When dampness or water leaks are major or frequent, the walls must be repaired before insulating. Before attempting repairs, seek the advice of your building material supplier or a contractor specializing in foundation repairs. *The best way to ensure a dry basement is to waterproof from the exterior.* If your basement walls require waterproofing repairs, you should consider insulating the walls from the outside at the same time as the walls are repaired from the exterior.

If your home is new, allow the concrete basement walls to cure for at least one year before insulating on the inside to avoid trapping moisture. (Concrete releases a tremendous amount of moisture during the first few months after it is poured.)

After you have dealt with any moisture problems, it is important to seal the basement walls to reduce heat loss due to air leakage; refer to pages 13 to 15 for details.

Applying the Moisture Barrier

To protect the insulation and framing materials from dampness or occasional water leaks in the basement walls, a moisture barrier is required. Although building paper or bituminous coating can be used, it is easier to use 0.15 mm (6-mil) polyethylene sheet as a moisture barrier. This barrier should extend from about 100 mm (4 in.) above the grade line down to the basement floor and under the bottom plate of the frame wall (see **Figure 12** on page 20). It is sealed to the wall with an adhesive or caulking (acoustical caulking works well with polyethylene), and supported with 19 x 64 mm (1 x 3 in.) strapping.

It is important that the moisture barrier only extend up to slightly above the grade line. This permits moisture within the frame wall and insulation to escape to the outside through the above grade area of the basement wall.

Do not caulk the moisture barrier to the basement floor. This will avoid trapping any water that may leak through the basement walls and onto the floor.

Figure 12

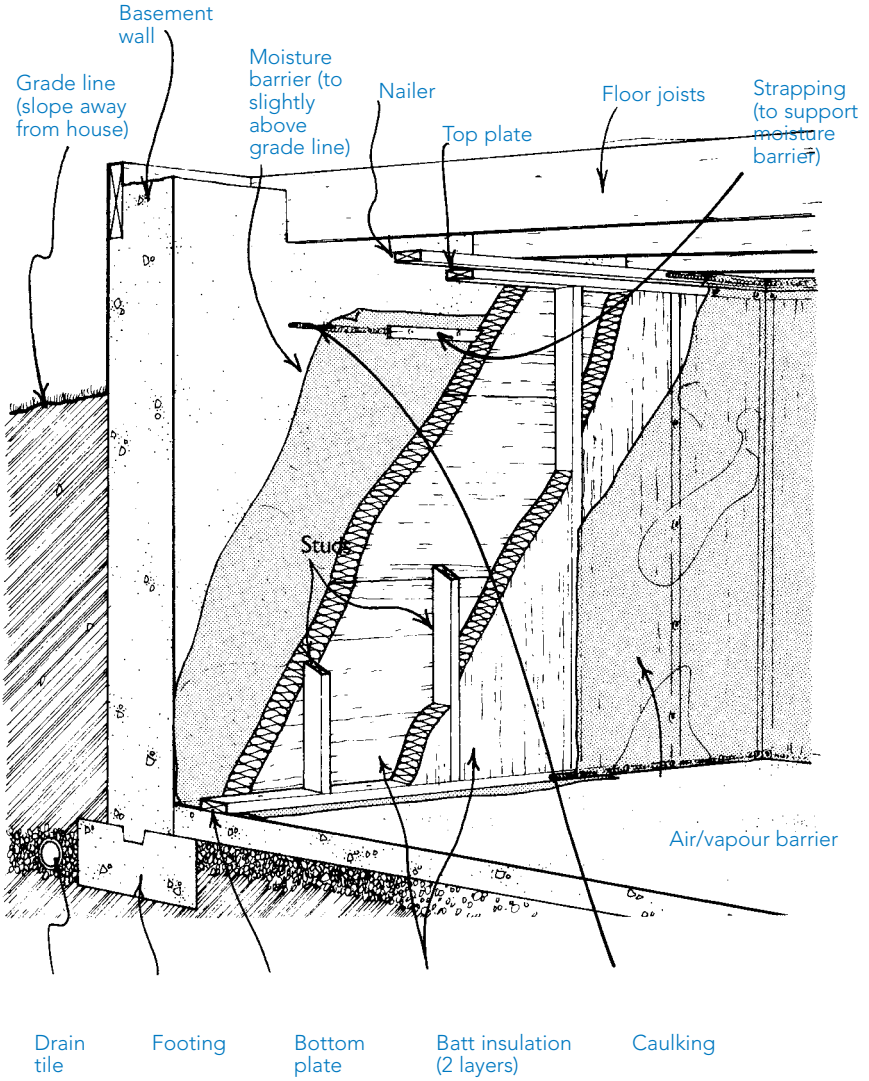

Framing the Walls

The next step is to install a wood frame wall to provide an insulation cavity, wiring space and support for the air-vapour barrier and interior finish. Use 38 x 89 mm (2 x 4 in.) studs at either 600 mm (24 in.) on centre (ie. from the centre of one stud to the centre of the next) or 400 mm (16 in.) on centre. The choice of spacing will depend upon how much structural support your finishing material needs. Use a single top and bottom plate with a single stud on either side of the window opening. Make sure that the studs are accurately spaced so that the insulation will fit snugly. Since the framing is non-load bearing and will be covered, relatively inexpensive, low grade lumber such as utility and stud grades can be used. If you frame the walls during the winter months, leave the lumber outdoors under cover until you are ready to use it (this will reduce warpage problems).

Begin by nailing a 38 x 89 mm (2 x 4 in.) nailer into the underside of the floor joists. Leave a 89 mm (3 1/2 in.) gap between the nailer and the inside face of the basement wall to allow for a layer of RSI 2.1 (R-12) batt insulation. Where the nailer is parallel to the floor joists, install blocking between the joists at 600 mm (24 in.) on centre to support the nailer (see **Figure 13** on page 22).

Build the wall framing on the floor in sections 2400 mm to 3000 mm (8 to 10 ft.) long; sections longer than this may be difficult to handle. If you haven't installed a moisture barrier as described on page 19, the bottom plate of the wall must either be pressure-treated preserved wood or regular framing lumber wrapped on the sides and bottom with polyethylene. This is necessary to prevent damage from moisture which may occasionally accumulate on the basement floor slab.

Because most Manitoba homes are built in areas with expansive clay soils, it is important to leave a 25 mm (1 in.) gap between the top plate of the frame wall and the underside of the floor joists nailer to accommodate possible vertical movement of the basement floor slab. This gap will also compensate for minor variations in the height between the floor slab and the underside of the floor joists.

Tilt the frame wall into place and temporarily brace. Drill holes through the top plate of the wall at every second or third stud space. Hammer 150 mm (6 in.) spikes through the holes and into the floor joist nailer. Leave 50 mm (2 in.) of the spikes exposed (see **Figure 13** on page 22).

Figure 13

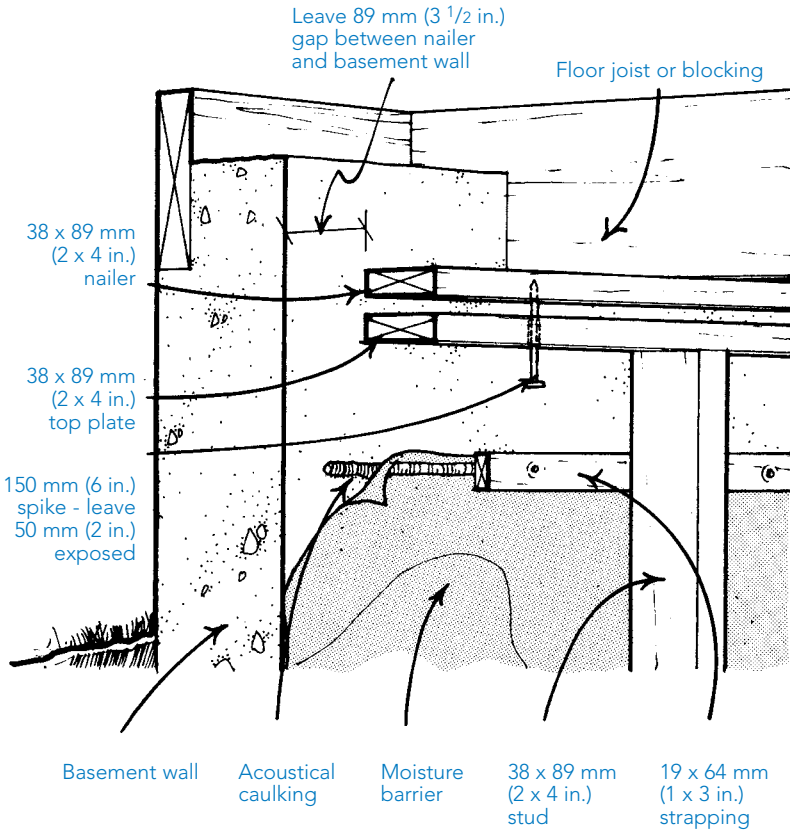

This will hold the wall firmly in place laterally at the top, yet still permit seasonal up-and-down movement of the floor slab.

Ensure the frame wall is vertical and fasten the bottom plate to the floor slab. Use either concrete nails or power-activated fasteners at every second or third stud space (see **Figure 14** on page 23).

If you are using new lumber, it may already contain significant amounts of water. If possible, allow the framing to dry indoors for several weeks *before* insulation is added and the wall covered with an air-vapour barrier.

Figure 14

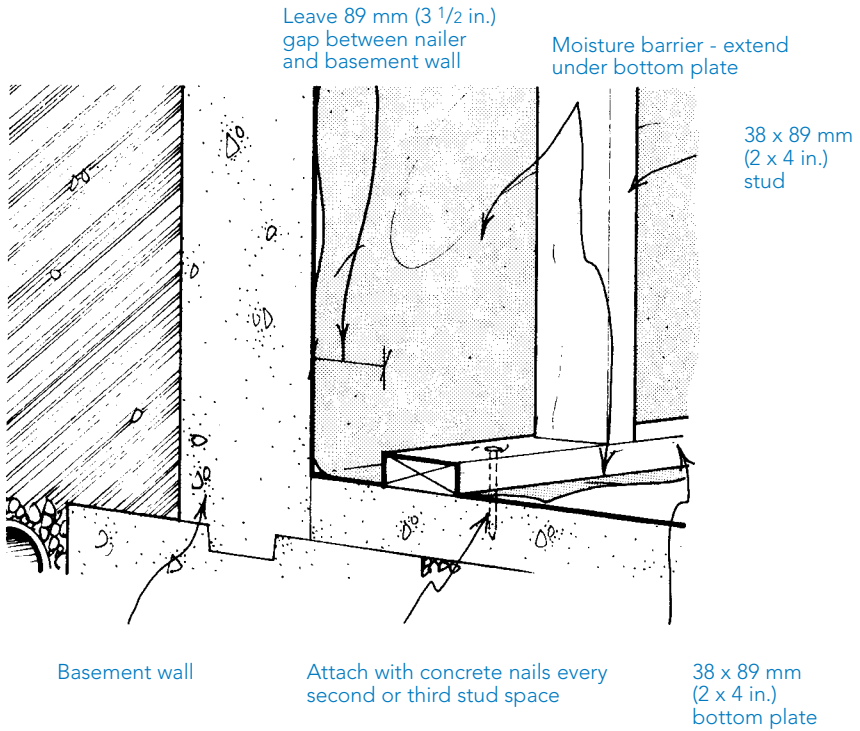

Special Details

Figure 15 (on page 24) shows two different framing options for bi-level homes.

In many homes, electrical panels, gas or water meters and plumbing lines pose particular problems. Moving them usually requires qualified personnel and may be expensive. The best solution often is to frame and insulate as close as possible to the obstruction and (where possible) use thinner rigid insulation behind the obstruction. Remember that most rigid insulations are flammable and must be covered with 13 mm (1/2 in.) drywall. *Be careful near electrical panels since they are still “live” even when the main switch is off.*

Figure 15

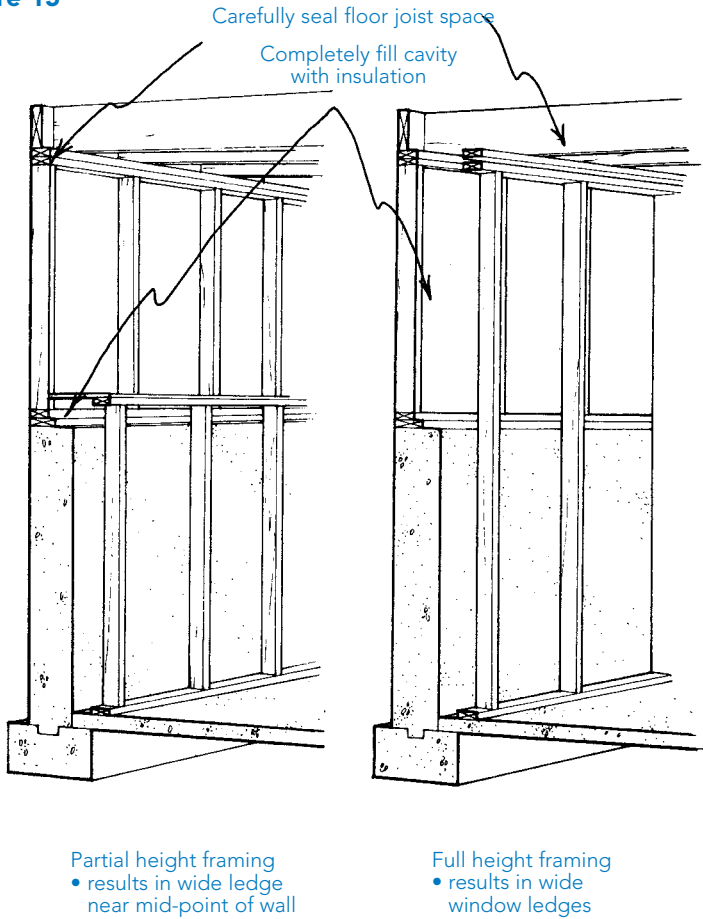

Framing to provide an insulation space around stairways, landings and built-in shelving may also pose problems. Each situation is unique and you may have to improvise. After the framing is completed, install any necessary electrical, telephone or cable television wiring in accordance with the electrical code. For information regarding wiring requirements, Winnipeg residents should call the City of Winnipeg at 986-3647, residents outside Winnipeg should call their local Manitoba Hydro office at 1 888 MB HYDRO.

Insulating the walls

The cavities behind and between the framing members can now be insulated with glass fibre batts. Completely fill all cavities to prevent air movement from reducing the effectiveness of the insulation. Make sure you cut the insulation pieces to the exact sizes required. Do not fold, overlap or compress any pieces to make them fit; this seriously reduces their insulating value.

The gap between the frame wall and the inside face of the basement wall can be filled with RSI 2.1 (R-12) insulation batts run horizontally. The 38 x 89 mm (2 x 4 in.) frame wall will accommodate another layer RSI-2.1 (R-12) insulation batts vertically between the studs. Purchase the insulation in a width to match the 400 mm or 600 mm (16 or 24 in.) spacing of the studs.

When the wall framing is being insulated, fill the joist space cavity as well. **Figure 16** (on page 26) shows how to seal and insulate three common types of floor joist/basement wall junctions. Note that if the floor joists are fully cast-in the basement walls, use a maximum of 25 mm (1 in.) of rigid insulation between the floor joists. If more insulation is used, the concrete between the floor joists will become much cooler, possibly making the floor above uncomfortably cool.

If there are accessible floor overhangs in your home, as there are in many bi-level homes or under bow and bay windows, make sure that these areas are fully insulated and well sealed similar to **Figure 9** (on page 17). (You may have to remove the soffit under the overhang to gain access.) An alternative is to hire a contractor to blow insulation in through holes drilled in the underside of the overhang or to apply rigid insulation to the underside of the overhang.

Applying the Air-Vapour Barrier

A continuous, well-sealed air-vapour barrier on the inner (warm) surface of the insulated frame wall is essential to prevent moisture problems and to reduce heat loss due to air leakage. This barrier is most easily provided by a 0.15 mm (6-mil) polyethylene sheet.

When installing the air-vapour barrier, overlap all joints by one joist or stud space. These overlaps and joists to electrical box covers should be caulked and stapled over solid backing (use non-skinning acoustical caulking). Use only enough staples to hold the polyethylene sheet in place. If necessary, edges, overlaps and joists can be reinforced with a strong tape before stapling as shown in **Figure 17** (on page 27). Tape alone should not be used for joints since it is difficult to achieve a tight and long lasting seal. Take care to join the air-vapour barrier from the frame wall to both the floor joist area and moisture barrier.

Figure 16

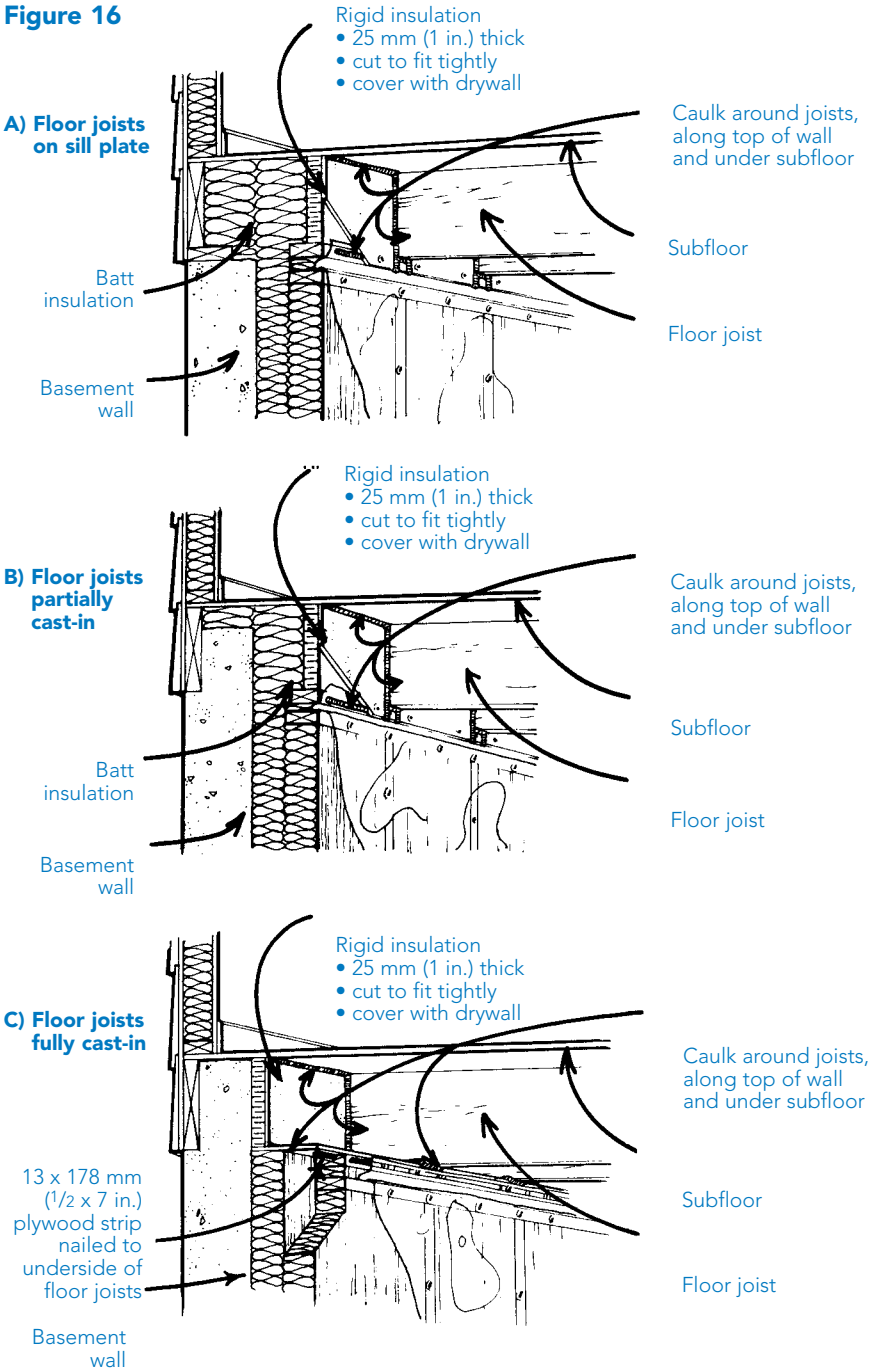
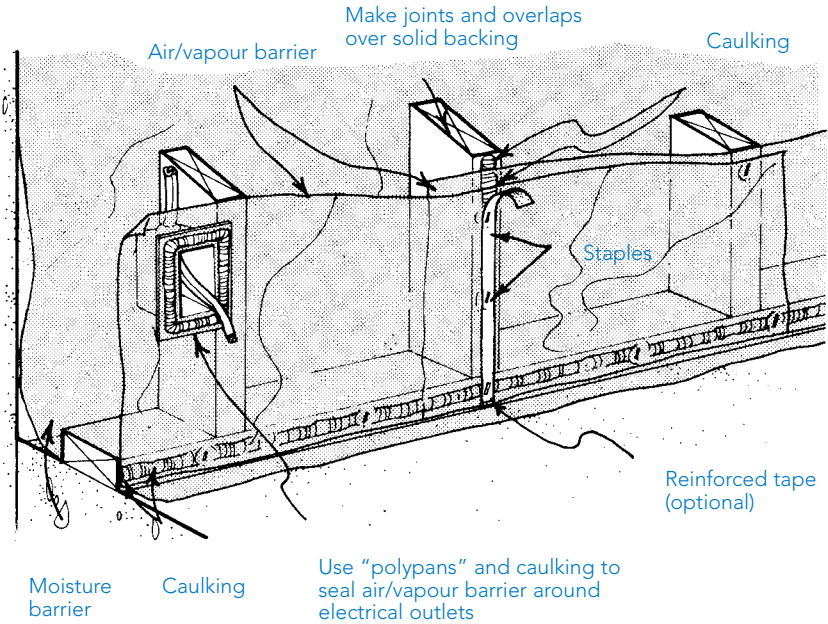

Figure 17



Polyethylene should not be exposed to sunlight for prolonged periods; the ultra-violet rays in the sunlight will prematurely age it. Once installed, the polyethylene air-vapour barrier should be covered as soon as possible to prevent damage from punctures, etc. If any tears or holes occur, repair them with large patches of polyethylene and acoustical caulking.

There are no limitations to the type of wall covering that can be applied unless rigid insulation has been used between the floor joists. Since most types of rigid insulations are flammable, they must be covered by 13 mm (1/2 in.) gypsum drywall (or equivalent) securely anchored to the structure.

Figure 18

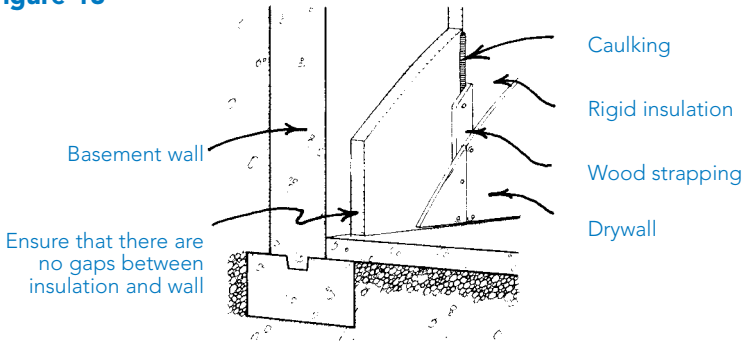

Inside Insulation without Framing

It is possible to insulate the basement walls from the inside without constructing a wood frame wall. As an alternative, rigid insulation panels (usually extruded or expanded polystyrene) can be fastened directly to the basement walls with adhesives or special metal channels and fasteners and then covered with 13 mm (1/2 in.) drywall.

This method takes up less space than a wood frame wall and is much quicker to build. However, it is an expensive system and can only be used if the basement walls are fairly even, vertical and without moisture problems. It is also more difficult to accommodate electrical wiring with this method.

In order to avoid problems with maintaining a secure bond (particularly in the event of fire), it is recommended that metal channels and mechanical fasteners be used to secure the gypsum drywall and insulation to the wall (in addition to or in place of adhesives).

Instead of using metal channels, wood strapping can be applied over the insulation with appropriate fasteners and spaced so as to form a base for applying the drywall with screws (see **Figure 18**).

If you purchase a prefabricated system with an attached fire-protective interior finish, carefully follow the manufacturer's instructions.

Basement Floors

Does It Pay to Insulate?

Insulating the basement floor in an existing home is usually difficult and rarely cost-effective. Most heat loss in a basement occurs in the upper portion of the exterior walls. The heat loss through the floor is minor by comparison.

Crawlspaces

Which Approach: Heated or Unheated?

A crawlspace can be insulated in either of two ways:

1. The walls of the crawlspace can be insulated, on the outside only, creating an additional heated area (see **Figures 19** and **20**).
2. The floor above the crawlspace could be insulated to reduce heat loss into the crawlspace in the first place (see **Figure 21** on page 31).

Figure 19

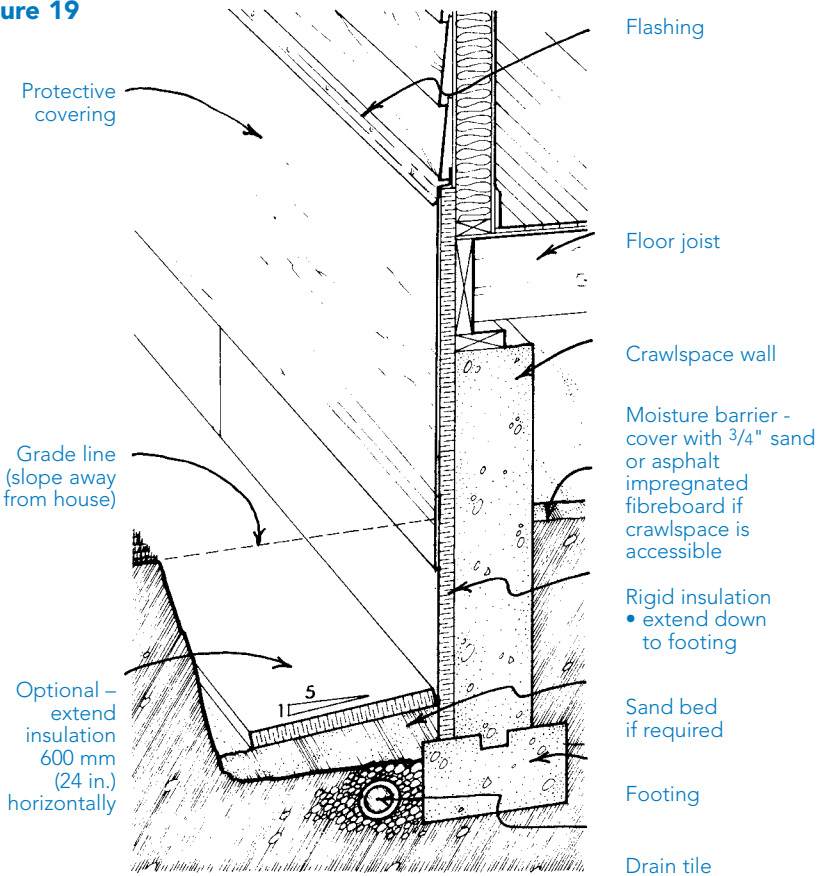
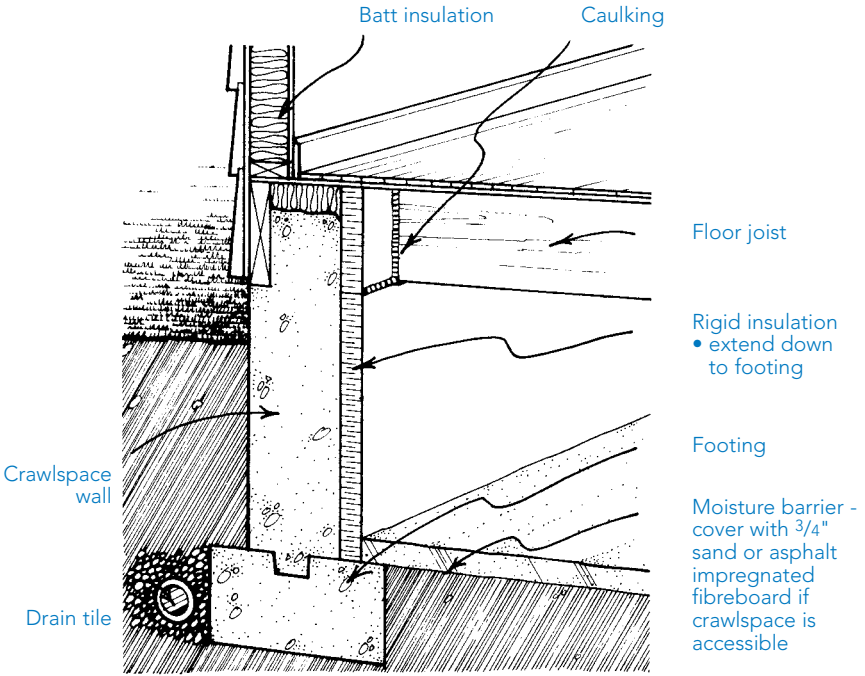

Figure 20



If the crawlspace moisture level is so high that it requires summer and winter ventilation (even with a moisture barrier on the floor), then the unheated crawlspace approach should be used. In most other cases creating a heated crawlspace by insulating the crawlspace walls (preferably from the outside) is recommended since:

- Heating ducts and water pipes in the crawlspace won't have to be insulated and are far less likely to freeze.
- By insulating on the outside, the crawlspace walls are not subjected to stresses from freeze-thaw cycles.
- Outside insulation also prevents damage from frost heave by keeping the soil below the crawlspace walls warm (an unheated crawlspace, or one insulated inside, will likely be surrounded by frozen soil).

Figure 21

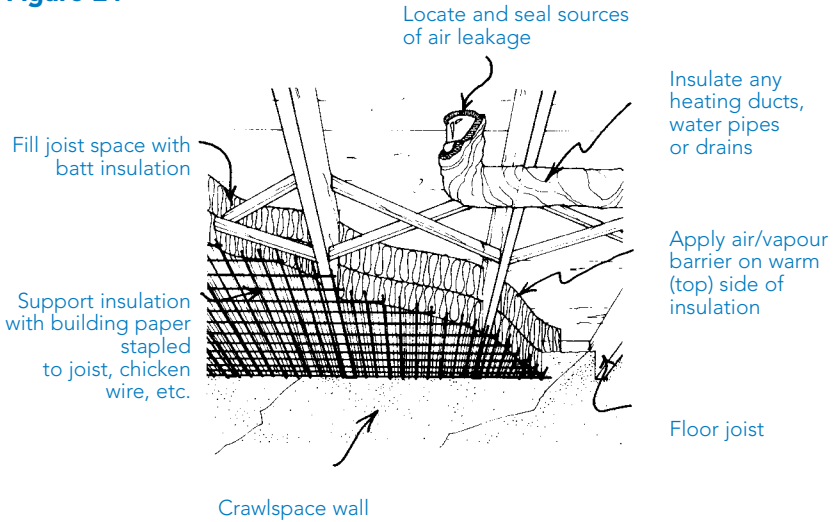

- It is usually easier to do a better insulating job on the exterior of crawlspace walls than the floor above the crawlspace, especially when the crawlspace is shallow or the joint spaces are uneven or oddly shapes.

With either approach, it is important to keep water away from the crawlspace walls to reduce the potential for frost heave and seepage problems. Slope the grade away from the house and install eavestroughs or extensions to downspouts where necessary.

Heated Crawlspaces — Insulating Outside

The technique for insulating on the outside of the crawlspace walls is similar to the technique previously described for insulating on the outside of basement walls (refer to pages 5 to 18).

If there is no moisture barrier on the crawlspace floor, add one. The barrier should be a 0.15 mm (6-mil) polyethylene sheet overlapped approximately 600 mm (24 in.) at the seams. The sheets should be held down with old boards, bricks or other material. If there is likely to be any traffic in the crawlspace, you will need to protect the polyethylene with a 50 mm (2 in.) layer of sand.

If your crawlspace does not open into a full basement, it should be ventilated during the warmer months to reduce moisture build up. The recommended ratio of vent area to floor area is 1-to-500. Make sure these vents are closed, well sealed and insulated each winter to reduce heat loss.

Heated Crawlspace — Insulating Inside

The easiest way to insulate a crawlspace from the inside is with rigid insulation. For advice on how to apply the insulation, refer to pages 9 and 10.

If the crawlspace is never used (and not accessible to children) and does not contain any mechanical equipment (pumps, etc.), it is not necessary to apply a fire-resistant covering such as 13 mm (1/2 in.) drywall over the rigid insulation.

Install a moisture barrier on the crawlspace floor and adequate ventilation as previously described on page 31.

Unheated Crawlspace

As previously indicated, this approach should be taken when the crawlspace is moist enough to require ventilation all year round, even with a moisture-barrier on the ground. To use this technique, follow these steps:

1. Apply a continuous, well-sealed air-vapour barrier on the warm (top) side of the insulation.

If the floor above the crawlspace is already covered with an impermeable material (e.g. linoleum), you already have a vapour barrier where you want it. Be sure to locate and seal any obvious air leaks.

If the floor is not covered with an impermeable material, consider applying a sheet of 0.15 mm (6-mil) polyethylene (seal the edges and joints between the sheets and acoustical caulking). A new floor finish can then be applied over the polyethylene.

2. Fill the space between the floor joists with glass fibre insulation (see **Figure 21**).

The insulation may be held in place by the use of building paper stapled to the joists, or by chicken wire, furring strips, fishing line or any other supporting material. If you have a problem with burrowing animals, you may want to protect the insulation by covering the underside of the floor joists with thin plywood or particle board sheathing.

It is preferable to secure the insulation firmly against the floor above. Also, be sure to fit the batts snugly between the joists so that air cannot circulate from the cold crawlspace to the warm floor and back again carrying heat.

3. Insulate heating ducts, water pipes and drains in the crawlspace.

Uninsulated water pipes may freeze after the floor has been insulated. Even insulated water pipes and drains may freeze if left unused and unheated for long periods of time. (Consider electrical heating tapes on pipes and drains if this becomes a problem.)

4. Install a moisture barrier on the crawlspace floor and install adequate ventilation as previously described on page 31.

Table 1 — Insulation Summary

Material	RSI/100 mm	(R/in.)
Batt or Blanket Type Insulation		
<p>Glass Fibre</p> <ul style="list-style-type: none"> Composed of long fibres of spun glass loosely woven together and bonded with resin. Sizes available: <ul style="list-style-type: none"> Batt Length 1.22 m (4 ft.) Blanket Length up to 21.5 m (80 ft.) Width 381 or 400 mm (15 or 16 in.) 584 or 610 mm (23 or 24 in.) Thickness 76 to 304 mm (3 to 12 in.) 	2.2	(3.2)
Loose Fill Insulation		
<p>Cellulose Fibre</p> <ul style="list-style-type: none"> Manufactured from finely shredded newsprint with chemicals mixed in to resist fire and fungal growth. 	2.5	(3.6)
<p>Glass Fibre</p> <ul style="list-style-type: none"> Similar material to glass fibre batts but chopped up for blowing purposes. 	2.0	(2.9)
<p>Rock Wool</p> <ul style="list-style-type: none"> Made from natural rock which is melted, made into fibres and bonded. 	1.6	(2.3)

Advantages

- Easy to install in standard joist and stud spaces.
- Dries with little effect if exposed to moisture.
- Moderate cost.
- Some products are non-combustible; check with manufacturer.
- Lightweight.
- Non-settling.

Limitations

- Does not fit readily into uneven spaces.
- Can irritate the eyes, skin and respiratory system during installation.
- Little resistance to air leakage.

- Easily fills irregular spaces.
- Has a higher resistance to air leakage than most insulations.
- Is the only blown-in insulation that can be installed by a homeowner with rented equipment.
- Low cost.
- Recycles newspaper.

- Permanently damaged if exposed to excessive moisture.
- Should not be installed in contact with high-temperature sources (e.g. chimney, recessed lights, etc.)
- Should not be covered with heavier types of insulation which may compress it.
- Eye and respiratory system irritant during installation.
- May settle.

- Easily fills irregular spaces.
- Has a light weight for its RSI-value.
- Dries with little effect if exposed to moisture.
- Some products are non-combustible; check with manufacturer.
- Low cost.

- Can irritate the eyes, skin and respiratory system during installation.
- Little resistance to air leakage.
- May settle.

- Easily fills irregular spaces.
- Highly resistant to fire.
- Dries with little effect if exposed to moisture.
- Low cost.

- Skin irritant during application.
- Low RSI-value per unit thickness
- Little resistance to air leakage.
- May settle.

Material	RSI/100 mm	(R/in.)
Loose Fill Insulation (cont'd)		
Mineral Wool <ul style="list-style-type: none"> • Similar to rock wool except raw material is industrial slag. 	2.1	(3.0)
Vermiculite <ul style="list-style-type: none"> • Mica material that has been expanded by a high temperature steam process. 	1.6	(2.3)
Wood Shavings <ul style="list-style-type: none"> • By-product of wood industries, shavings are often mixed with lime and other chemicals. 	1.7	(2.5)

Rigid Board Insulation

Glass Fibre Board <ul style="list-style-type: none"> • Similar to glass fibre batts except formed into rigidboards. • Usually faced on one side with a material that is permeable to water vapour and impermeable to air movement. • Sizes available: <ul style="list-style-type: none"> Length 2.4 or 3 m (8 or 9 ft.) Width 1.2 m (4 in.) Thickness 25 to 28 mm (1 to 1¹/₂ in.) 	2.9	(4.2)
---	-----	-------

Advantages

- Same as rock wool.
- Easiest loose fill insulation to fill irregular spaces.
- Highly resistant to fire.
- Usually low cost if locally produced.
- Recycles wood waste.

Limitations

- Same as rock wool.
- High cost.
- Absorbs moisture and dries slowly.
- Low RSI-value per unit thickness
- May settle.
- Difficult to treat against fire, vermin and fungus growth.
- Absorbs moisture and dries slowly.
- Should not be installed in contact with high-temperature sources. (e.g. chimney, recessed lights, etc.)
- Low RSI-value per unit thickness
- May settle.

- Easy to handle and install.
- Some products are non-combustible; check with manufacturer.
- High RSI-value per unit thickness.

- High cost.
- More compressible than other rigid board insulations.
- Skin irritant during installation.
- Tedious to fit an irregular space.

Material	RSI/100 mm	(R/in.)
Rigid Board Insulation (cont'd)		
<p>Extruded Polystyrene</p> <ul style="list-style-type: none"> • A foam plastic board composed of fine, closed cells containing a mixture of air and refrigerant gases (fluorocarbons). • Sizes available: <ul style="list-style-type: none"> Length 1.2 or 2.4 m (4 or 8 ft.) Width 406 or 610 mm (16 or 24 in.) Thickness 25, 38, 51 or 78 mm (1, 1½, 2 or 3 in.) 	3.5	(5.0)
<p>Expanded Polystyrene (“Beadboard”)</p> <ul style="list-style-type: none"> • Produced by a process that results in beads containing air, bonded together into rigid, foam plastic boards. • Sizes available: <ul style="list-style-type: none"> Length 1.2, 2.4 or 2.7 m (4, 8 or 9 ft.) Width 406, 610 or 1220 mm (16, 24 or 48 in.) Thickness 19 to 152 mm (¾ to 6 in.) 		
<p>Polyurethane and Polyisocyanurate Boards</p> <ul style="list-style-type: none"> • A foam plastic board with primarily closed cells filled with refrigerant gases (fluorocarbons). • Usually foil-faced on both sides to strengthen the board and retain the gases which give it a high RSI-value • Sizes available: <ul style="list-style-type: none"> Length 2.4 m (8 ft.) Width 1.2 m (4 ft.) Thickness 25, 38 or 51 mm (1, 1½ or 2 in.) 	4.2	(6.0)

Advantages

- Most moisture resistant rigid board insulation.
- Easy to handle and install.
- Can perform as an air-vapour barrier when installed on interior side of insulated cavities if joints are sealed properly.
- High RSI-value per unit thickness.

- Lowest cost per RSI-value of all the rigid insulation boards.
- Easy to handle and install.

- Highest RSI-value per unit thickness of all rigid insulation boards.
- Easy to handle and install.
- Can perform as an air-vapour barrier when installed on interior side of insulated cavities if joints are sealed properly.

Limitations

- High cost.
- Can be a fire hazard unless properly covered.
- Must be protected from exposure to sunlight or solvents.
- Tedious to fit in an irregular space.

- Can be a fire hazard unless properly covered.
- Must be protected from exposure to sunlight or solvents.
- Tedious to fit in an irregular space.

- Very high cost.
- Can be a fire hazard unless properly covered.
- Must be protected from exposure to sunlight or solvents.
- Loses some thermal resistance as it ages.
- Tedious to fit in an irregular space.

Metric Conversion Factors

A. Converting Imperial Units into Metric Units

Unit	Conversion	Multiply By
Thermal Resistance	R values to RSI values	0.1761
Length	inches to millimetres	25.40
	inches to centimetres	2.540
	feet to metres	0.3048
Area	square feet to square metres	0.09290
Volume	gallons to litres	4.546
	cubic feet to cubic metres	0.02832
Mass	pounds to kilograms	0.4536
Density	pounds/cubic feet to kilograms/cubic metre	16.02

B. Converting Metric Units into Imperial Units

Unit	Conversion	Multiply By
Thermal Resistance	RSI values to R values	5.678
Length	millimetres to inches	0.03937
	centimetres to inches	0.3937
	metres to feet	3.281
Area	square metres to square feet	10.76
Volume	litres to gallons	0.2200
	cubic metres to cubic feet	35.31
Mass	kilograms to pounds	2.205
Density	kilograms/cubic metre to pounds/cubic foot	0.06243

If you are uncertain of, or have any question or concern regarding, any subject matter herein or the safety and/or proper handling of any material(s) and/or product(s) that you may encounter in your undertaking, please consult resources such as Health Canada (Health Links) @ 1-888-315-9257, the Manitoba Department of Labour @ 1-800-282-8069, or CMHC (Canada Mortgage & Housing Corp.) @ 1-800-668-2642.

The information contained herein is published as a convenient reference for Manitoba Hydro's customers. While every effort has been made to provide accurate and complete information, Manitoba Hydro does not warrant the accuracy or efficacy thereof. Manitoba Hydro will not be liable for any loss, costs, damage or injury whatsoever, resulting from the use of this material.

Cette information est également disponible en français.

