

3

POWER SMART GUIDE:
Energy saving solutions for home comfort

Attic insulation



 **Manitoba
Hydro**
POWER SMART[®]

*Manitoba Hydro is a licensee of the Trademark and Official Mark.

For more information on Power Smart:

Telephone: (204) 480-5900 in Winnipeg

Toll-Free: 1 888 MBHYDRO (1-888-624-9376)

Or visit www.hydro.mb.ca

Publications in this series

- ① Sealing, Caulking & Weatherstripping
- ② Basement & Crawlspace Insulation
- ③ Attic Insulation
- ④ Wall Insulation
- ⑤ Doors & Windows
- ⑥ Heating Systems
- ⑦ Water Heaters
- ⑧ Indoor Air Quality & Ventilation
- ⑨ Low Cost No Cost Energy Savings Tips



BOOKLET #3

Attic Insulation

Contents

Introduction

Why Retrofit?	2
Do-It-Yourself or Hire A Contractor	3

Checking Your Attic

Precautions Before Starting	4
How to Inspect Your Attic	5
• Gaining Access	5
• Checking for Roof Leaks	6
• Existing Insulation	7
• Air Leaks	7
• Vapour Barriers	9
• Ventilation	10

Preparing the Attic Space

Tools Required	11
Step One: Reduce Air Leakage	11
Step Two: Ensure Adequate Ventilation	17

Insulating the Attic Space

Accessible Attics	20
• Installing Batt Type Insulation	20
• Installing Loose Fill Insulation	22
• Additional Points When Insulating	23
Storey-and-a-Half Attics	24
• Outer Attic Floor and Attic Ceiling	24
• Kneewalls	25
• End Walls	26
• Sloped Ceilings	26
Cathedral and Flat Ceilings	27
• Insulate Below the Existing Ceiling	27
• Insulate Above the Existing Roof	28
• Build A New Peaked or Sloped Roof	29

Tables

Table 1 — Insulation Summary	30
Table 2 — Ventilation Requirements	38

Introduction

Why Retrofit?

Save Money — Heating a home, especially in our climate, can be expensive. Most of the homes in Manitoba were constructed during an era of plentiful and inexpensive energy supplies. As a result, these homes were built with only a small amount of attic insulation. With today's much higher energy costs, retrofitting your home's attic is often one of the least costly and most effective ways to reduce your energy bills.

Increase Comfort — A well-insulated house is a comfortable house. A properly insulated attic pays dividends year-round; your home will not only be warmer in the winter, but it will also be cooler and more comfortable in the summer.

Conserve Energy — Approximately 13% of Manitoba's annual energy use goes to heat our homes. Much of that energy can and should be saved. Retrofitting your home will help save our valuable energy resources at a cost lower than producing new energy supplies.

In addition to these major benefits, retrofitting often can also improve the appearance, longevity, and safety of your home.

Do-It-Yourself or Hire A Contractor

This booklet has been designed to meet the needs of both the experienced and the inexperienced "do-it-yourselfer". Most of the work described can be done by a homeowner with common household tools. By doing it yourself, both the savings and job satisfaction can be high. Please read this booklet carefully. For additional information, please contact us (see inside front cover) or your local building material supplier.

If you intend to have a contractor do some or all of the work, this booklet will still be of interest to you. You are more likely to get the results you want if you are knowledgeable about the work and take an active interest in what the contractor does. For further information on how to hire a contractor, call the Consumers' Bureau at 945-3800 (Winnipeg), toll-free 1-800-782-0067 or e-mail consumersbureau@gov.mb.ca.

Figure 1

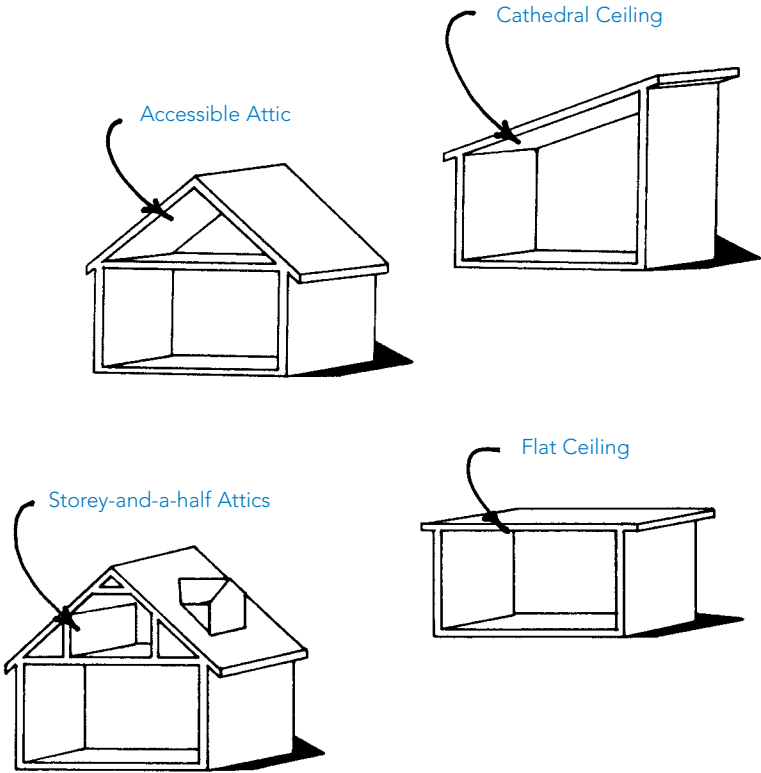

The types of attics and ceilings discussed in this booklet are illustrated in **Figure 1**. Whether you do-it-yourself or hire a contractor, please remember that this booklet does not describe every possible technique for insulating an attic.

Each home is unique and you or your contractor may find it necessary or desirable to deviate from the techniques shown in this booklet.

Checking Your Attic

Precautions Before Starting

Before you tackle the job of checking and retrofitting your attic, make sure you are familiar with the following safe working procedures:

- Provide good lighting (preferably a fluorescent trouble light, since an exposed incandescent bulb can ignite some types of insulation).
- Lay boards down over the tops of the joists or trusses to form a walkway as shown in **Figure 2** (the ceiling below won't support your weight).
- Wear a dust mask.
- Wear gloves and thick, loose clothing with long sleeves and tight cuffs to minimize skin irritations when handling insulation.
- Wear goggles if there is a possibility of insulation dust coming in contact with your eyes.
- A hard hat can be worn to keep insulation particles out of your hair and to prevent head injuries.
- Locate all electrical wiring in your attic, and then avoid all unnecessary contact with it. If it doesn't look safe (cracked covering, bare wires, open junction boxes) have it inspected by a qualified electrician.

Figure 2

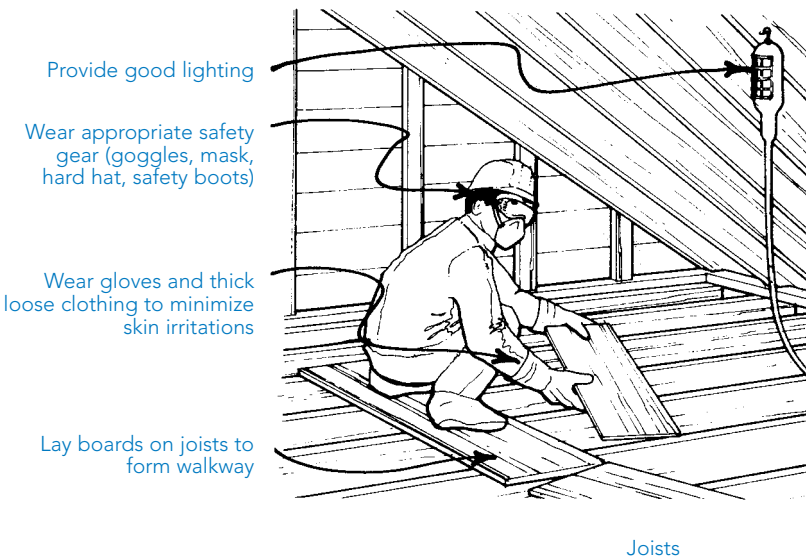

- Most rigid insulations are very flammable and should be kept well away from sources of heat. If used indoors, cover any exposed rigid insulation with 13 mm (1/2 in.) gypsum wallboard or equivalent.
- If there are nails protruding from the attic floor, wear safety boots. Otherwise wear shoes with good traction (running shoes).
- Use ladders correctly; support them properly and have a helper steady them.
- If you work on the roof, use a safety rope tied to a secure place.
- The attic in your home can be very hot during the summer. Work on cool spring or fall days, or on cool summer evenings.
- When cleaning up insulation fibres or dust, use a vacuum cleaner. If you can only sweep up the material, dampen it first to prevent particles from becoming airborne.
- After the work is complete, vacuum your work clothes and then wash them separately from other clothing.

How to Inspect Your Attic

The first step is to determine what condition your attic is in now. A good understanding of what shape your attic is in will be essential in planning what has to be done, and in choosing the best materials or selecting the proper contractor.

You'll need to determine the type, amount and condition of existing insulation. You should also assess whether the attic is properly vented or if it has a moisture problem.

The next few pages describe how to inspect your attic to determine your retrofitting needs.

Gaining Access

Most homes have interior access doors or hatches that lead to the attic. *A good job of inspecting and insulating the attic depends on being able to gain access to all parts of the attic.* If your home lacks access to any portion of the attic, consider one of the following options:

- Cut into the attic from outside the house. This can be done by cutting a hole in one of the gable ends. A large attic vent mounted in a small door can fill the opening. Be sure to add flashing and caulking to ensure that rain water can't penetrate into the attic.

- Consider cutting into the attic from inside the house. The hole can be made into a decorative hatchway or it can be located in an out-of-the-way place such as a closet or hallway. Be careful not to make entry too difficult. If the hatchway is too close to the perimeter of the attic, there may be insufficient headroom above the hatch. Plan the job carefully. First, cut a small hole and check to make sure that no wires or structural supports will be damaged. Then cut the hatchway so that it spans between adjacent joists and is as wide as possible in the other direction — up to one meter.

In some cases, there may not be sufficient space in which to work. Evaluate the condition of the attic as best you can in these circumstances. If additional insulation is required, it can be blown in.

Finally, some houses may not have an open attic above part or all of the house (e.g. cathedral ceilings, flat roofs, sloped ceilings in 1½- and 2½-storey homes). To assess the type, amount and condition of insulation, you can drill small inspection holes in an out-of-the-way place such as a closet or hallway.

Checking for Roof Leaks

After gaining access to the attic, check for roof leaks. The effectiveness of most insulations is severely reduced by moisture. Any leaks in the roof must be repaired *before* adding insulation.

Common causes of roof leaks include faulty roof flashing, wornout shingles and improperly installed attic vents. Look for clues such as wetness or water stains on the underside of the roof, wet insulation, or stains on the ceiling below. The best time to check for these signs of roof leaks is during or just after a rain storm.

Be careful not to confuse signs of condensation with the effects of moisture from a leaky roof. An explanation of what causes condensation is given in the section “Air Leaks” on page 7.

Roof leaks can also be the result of *ice dams* forming along the eave or valley of a roof during winter or early spring. These ice dams cause water to back up under the shingles and leak into the attic. Ice damming can usually be reduced by sealing and insulating the attic, and by clearing and improving the ventilation. In severe cases, it may be necessary to install electric heating cables on the roof or add moisture protection under the shingles along the eaves and valleys. If your home suffers from ice damming, get advice from a roofing contractor with expertise in dealing with this problem.

Existing Insulation

Insulation should be in good condition — evenly distributed and dry. Many old houses will have unusual insulation, such as peat moss or old newspapers. Whatever the kind, if it is not wet, leave it, since new insulation can be added on top. *If it is wet, remove it altogether.*

Measure the average depth of the existing insulation with a ruler in several locations. Calculate the total insulation value using the RSI value (R-value) shown in **Table 1** (on page 30). If you have trouble identifying the insulation type, take a small sample to a local building supply outlet for help.

Attics which are open and easily accessible should be insulated to a minimum of RSI-8.8 (R-50). If the existing insulation is close to this value (say RSI-5.3 (R-30) or better) additional insulation may not be cost-effective as it will only result in a small reduction in heat loss.

If your home has a flat ceiling, sloped ceiling (as in a 1^{1/2}- and 2^{1/2} storey homes) or cathedral ceiling, it should be insulated to a minimum of RSI-5.0 (R-28). Unfortunately, it is difficult and expensive to add insulation to these types of ceilings. However, if combined with general renovations or roof replacement, additional insulation can become economically attractive.

If your attic is inadequately insulated, add insulation as described later in this booklet.

Air Leaks

Check diligently for any air leaks into the attic from the house so that they can be sealed prior to insulating, as described later in this booklet.

If there is evidence of moisture damage in the attic, such as wet insulation, yet the roof appears free from leaks, suspect condensation from excessive air leakage. During the winter, warm air which escapes from the house can carry significant amounts of water vapour into the cold attic where it may form *condensation* or frost. If excessive, this moisture can seriously damage the insulation and attic framing.

When searching for air leaks it might help to turn off your flashlight or trouble light and look for light from below. Some common locations of air leaks (see **Figure 3**) worth investigating include:

Figure 3 • Typical air leakage paths into an attic

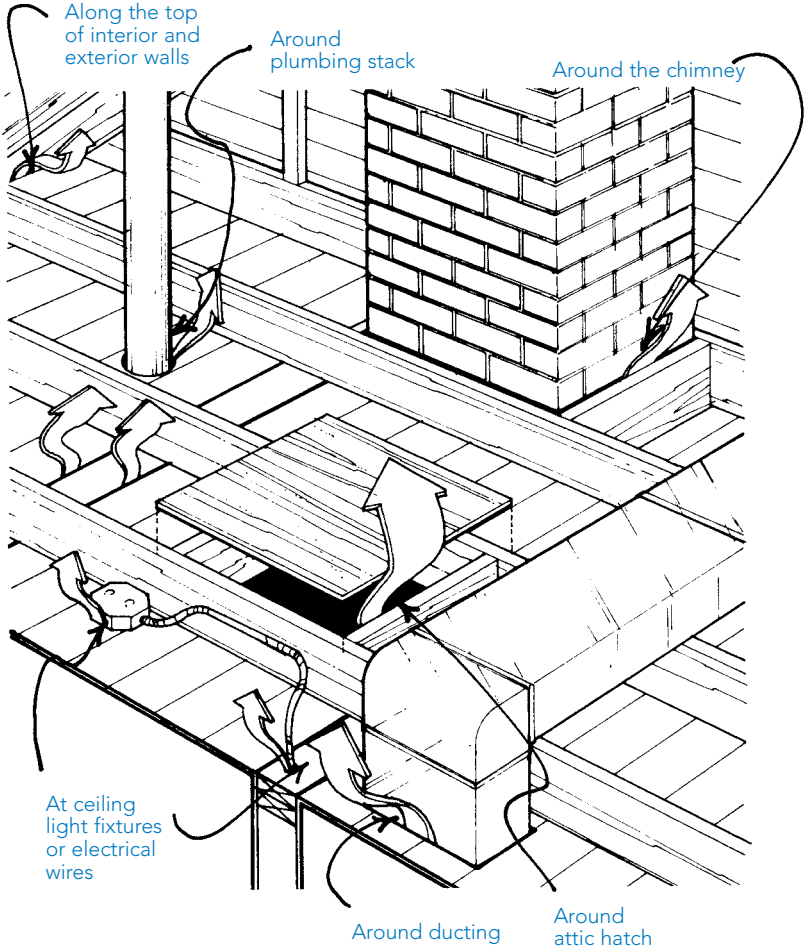

- **Around the plumbing stack** and other pipes entering the attic.
- **Around electrical wires or ceiling light fixtures** that penetrate the attic floor (Be careful!).
- **Around ducting that enters the attic from inside the house** — from kitchen exhaust fans, bathroom vents, etc. (Joints in the ductwork itself should be sealed with duct tape. The ductwork should be wrapped with at least 100mm (4 in.) of insulation to prevent condensation. It is especially important that *no exhaust fans discharge into the attic*. They should discharge to the outside, but not directly below the eave vents).
- **At the junction of the ceiling and interior wall partitions.** Pull back the insulation where necessary to check for cracks formed along interior walls.
- **At the top of interior and exterior walls.** Check to see if all the wall cavities are blocked from the attic (usually by a top plate).
- **Around attic hatches.** Hatches should be weatherstripped as you would a door to the outside. The hatch should also be sealed around the frame and between the casing and the ceiling.
- **Around the chimney.** *Chimneys should not be sealed with any material that is (or may become) flammable.* Page 16 describes how the gap around a chimney should be sealed.

Also remember that any openings made for inspection purposes are also potential sources of air leaks. They should be patched and sealed as soon as they are no longer required.

Vapour Barriers

While checking for air leaks, note whether there is a vapour barrier on the attic floor. The vapour barrier will probably be either a layer of kraft or waxed paper or, in more recently constructed homes, polyethylene.

The vapour barrier protects the attic insulation and framing by reducing the movement of water vapour by *diffusion* from the house to the attic (Diffusion is the movement of water vapour through a permeable material. Because kraft or waxed paper and polyethylene are relatively impermeable to water vapour, they are classified as vapour barriers).

If your home does not have a kraft/waxed paper or polyethylene vapour barrier, it still is possible to provide adequate moisture protection. In these cases, seal all air leaks through the ceiling, as described later in this booklet, and then paint the underside of the ceiling with two coats of a low-permeability paint (oil, enamel or latex vapour barrier paint).

It is also important to maintain a reasonable level of humidity in the home during winter in order to protect the attic from excessive moisture.

If there is an existing vapour barrier, patch any obvious breaks and seal air leaks as described later in this booklet before adding insulation.

Ventilation

Attic ventilation serves two basic purposes:

1. **In summer, ventilation will keep the attic cooler.** This will make your home more comfortable and, if you have air conditioning, reduce your electrical bills. Ventilation may also extend the life of your roof.
2. **In winter, ventilation allows moisture which migrates from the house and into the attic to escape to the outdoors.** This protects the insulation and roof framing from damage. Adequate ventilation also reduces the risk of damage due to ice damming.

Take note of the type, location and approximate size of existing vents in your home's attic. Make sure that the vents are not blocked by insulation, dirt or other materials. It may be necessary to first locate any roof or soffit vents from outside the house if they are not clearly visible from inside the attic.

Vents should be evenly distributed to give good cross-ventilation from end-to-end and from bottom-to-top of the attic space. **Table 2** (on page 38) lists the recommended ventilation areas required for various types of attics. Note that the ventilation area must be increased if the vents are covered with screening (to keep out insects and birds) or with louvres (to keep out rain and snow).

If your attic is inadequately vented, upgrade the ventilation as described later in this booklet.

Preparing the Attic

Tools Required

- Basic carpentry tools (hammer, level, carpenter's square, caulking gun, stapler, saw).
- Temporary lighting.
- Temporary floor boards.
- Utility knife and metal straightedge.
- Rake or similar tool to manoeuvre insulation into place around eaves when there isn't enough headroom.
- Safety equipment (goggles, gloves, hard hat, mask).

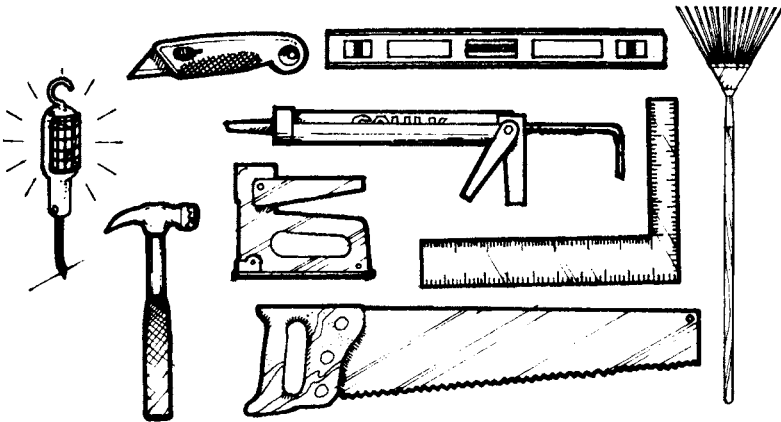

Step One: Reduce Air Leakage

Before adding any insulation, seal as many potential sources of air leakage as possible. It is important to spend a little extra time and be thorough when doing this work. As previously described, excessive air leakage not only adds to your heating bills but can also carry significant amounts of moisture into the attic where it can damage the insulation and framing.

Methods of sealing common sources of air leakage are listed below and illustrated in **Figures 4 to 10** (pages 12 to 17). Another publication in this series entitled *Sealing, Caulking and Weatherstripping* (Booklet #1) provides additional information on the types and applications of caulking and weatherstripping material.

Figure 4

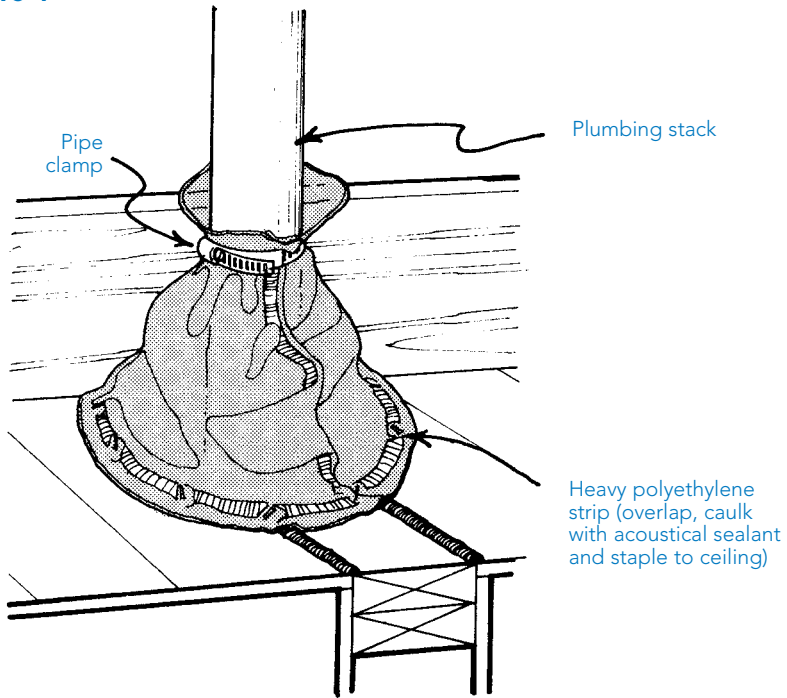

- **Plumbing Stack** — This is difficult to seal because it is subject to expansion and contraction as warm water flows through it. Use a flexible seal consisting of acoustical sealant, heavy polyethylene (0.15 mm - 6-mil), a hose clamp, and staples as shown in **Figure 4**.
- **Electrical Wires and Ceiling Light Fixtures** — Caulk electrical wires where they penetrate the attic space as shown in **Figure 5**. Electrical boxes for ceiling light fixtures can be sealed with pieces of 0.15 mm (6-mil) polyethylene, acoustical sealant, and staples as shown in **Figure 5**. Alternatively, ceiling light fixtures can be sealed with caulking or CSA-approved foam gaskets from the interior as shown in **Figure 6**. If your home has recessed lights, refer to page 23 for advice.

Figure 5

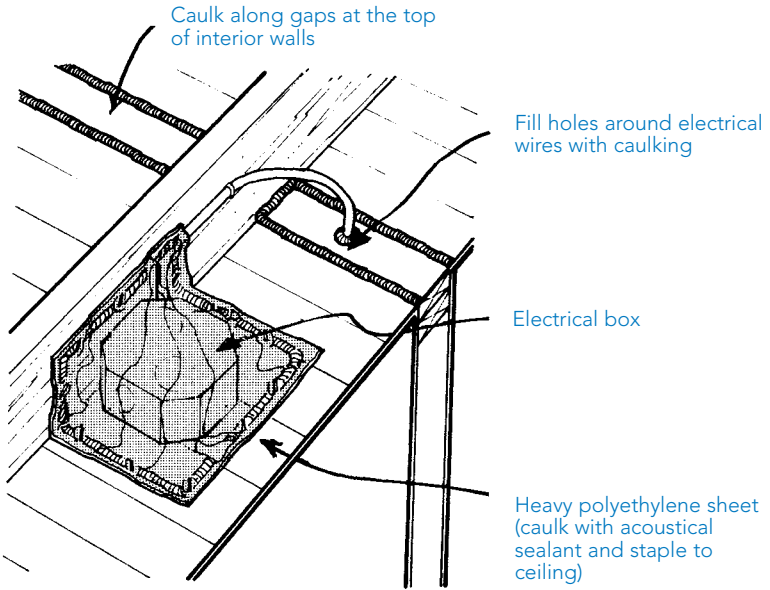

Figure 6

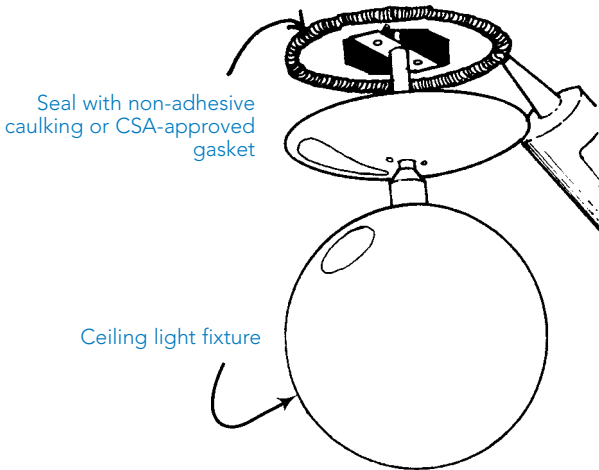
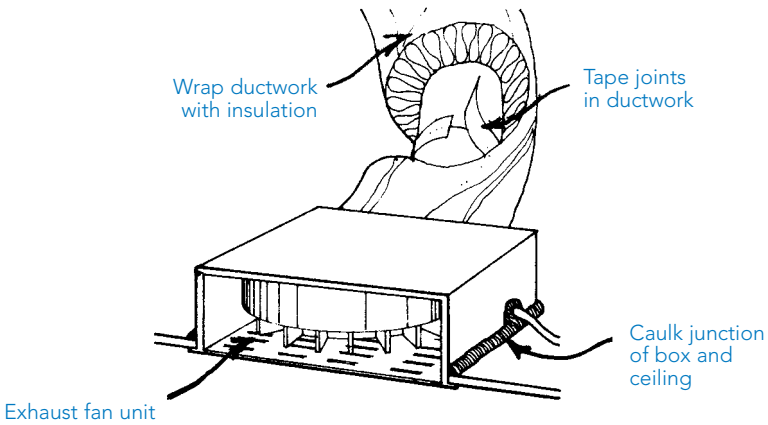

Figure 7



- **Exhaust Fans and Ducts** — Seal exhaust fans where they penetrate the attic as illustrated in **Figure 7**. Joints in the ductwork should be sealed with duct tape. To prevent condensation within the ductwork, make sure it is wrapped with at least 100 mm (4 in.) of insulation.
- **Junction of the Ceiling and Interior Partitions** — Seal any gaps with caulking (refer back to **Figure 5** on page 13).
- **At the Top of Interior and Exterior Walls** — Wall cavities which are open to the attic should be sealed with wood blocking and caulking as shown in **Figure 8**. Top plates on walls which are cracked or poor fitting can be sealed with caulking and polyethylene.
- **Around Attic Hatches** — Weatherstrip the hatch as you would a door to the outside, as shown in **Figure 9**. Use latches to hold the hatch snugly against the weatherstripping. Caulk around the ceiling trim of the hatchway.

Figure 8

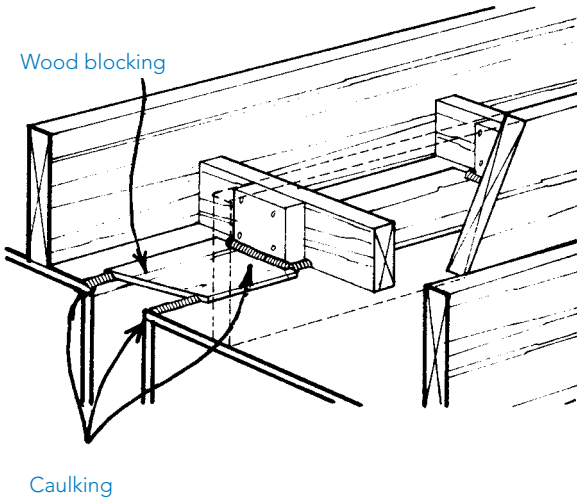

Figure 9

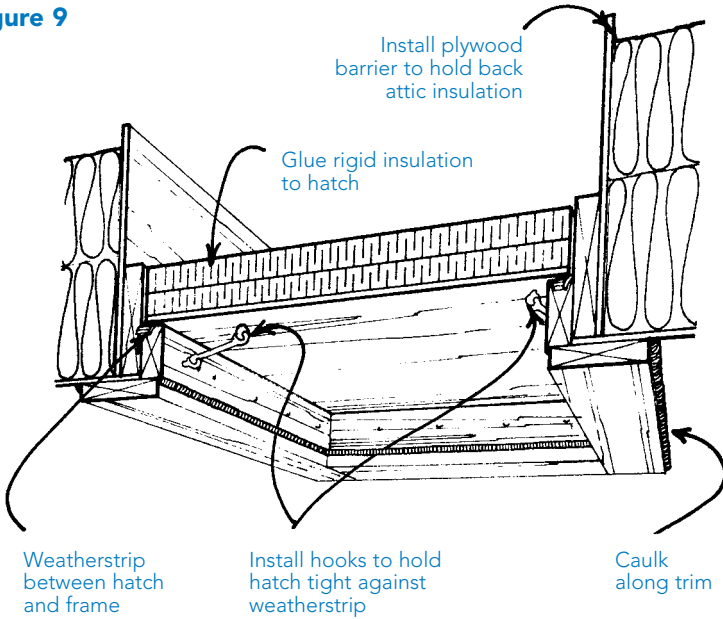
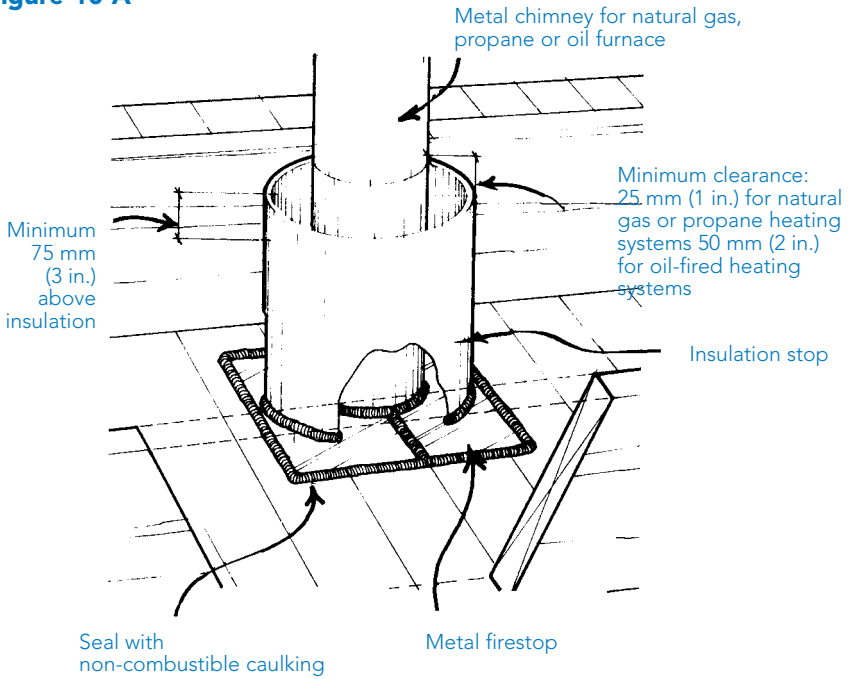

Figure 10 A



- **Around the Chimney** – Seal as shown in **Figures 10A** and **B**. *Do not use any material that is (or may become) flammable.* Large gaps can be bridged by sheet metal. All joints should be sealed with a flexible, heat-resistant caulking or stove cement. Keep insulation at least 25 mm (1 in.) away from the chimney for natural gas or propane heating systems. For oil-fired heating systems, maintain a minimum gap of 50 mm (2 in.). Use a metal or gypsum drywall insulation stop that protrudes at least 75 mm (3 in.) above the upgraded insulation level.

For information on sealing around metal chimneys for wood-burning fireplaces, stoves or furnaces, contact the chimney supplier or manufacturer. If this is not possible, contact Manitoba Labour - Office of the Fire Commissioner at 945-3322.

Figure 10 B

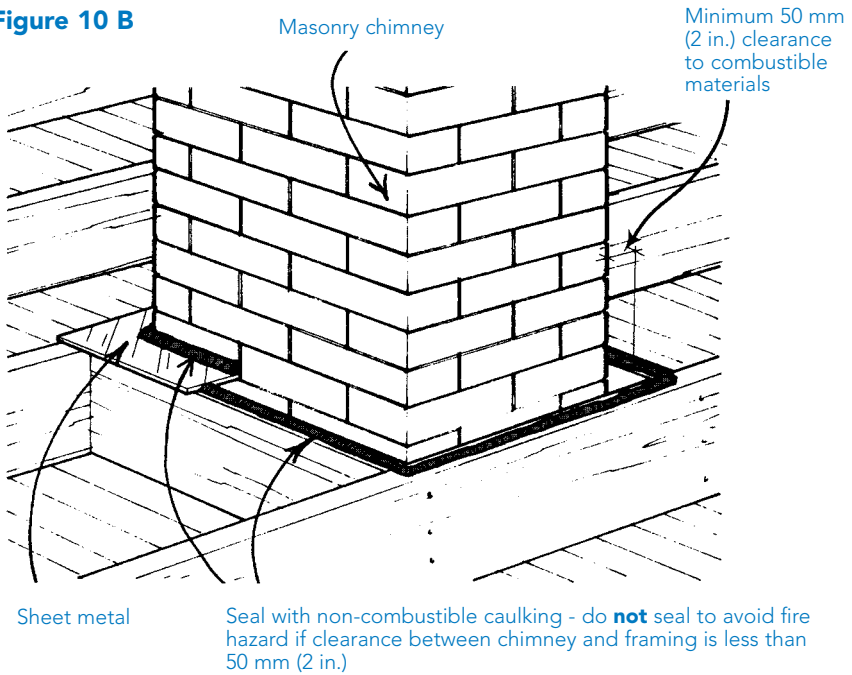

Step Two: Ensure Adequate Ventilation

After sealing as many potential sources or air leakage as possible, the next step before adding insulation to the attic is to ensure adequate ventilation. As previously noted, proper ventilation will keep the attic cooler in summer and allow moisture that migrates from the house and into the attic to escape to the outdoors during winter.

Use **Table 2** (see page 38) to determine how much additional venting is required. Locate the additional vents to give good cross-ventilations from end to end and from bottom to top of the attic space. This means that, ideally, vents should be located at the eaves and at the peak of the roof.

Figure 11 (see page 18) illustrates three types of peak vents — on the ridge, at the gable end and on the roof. Although any of these peak vents are adequate when used in conjunction with under-eave (soffit) vents, continuous-ridge vents are preferred where practical.

It is recommended that 50% of the ventilation area be soffit vents and that the other 50% be ridge, gable-end or roof vents. If practical, the soffit vent should be continuous. When installing soffit vents, install insulation stops to ensure that cold outdoor air flows up and over the insulation rather than through it (see **Figure 12**).

Figure 11

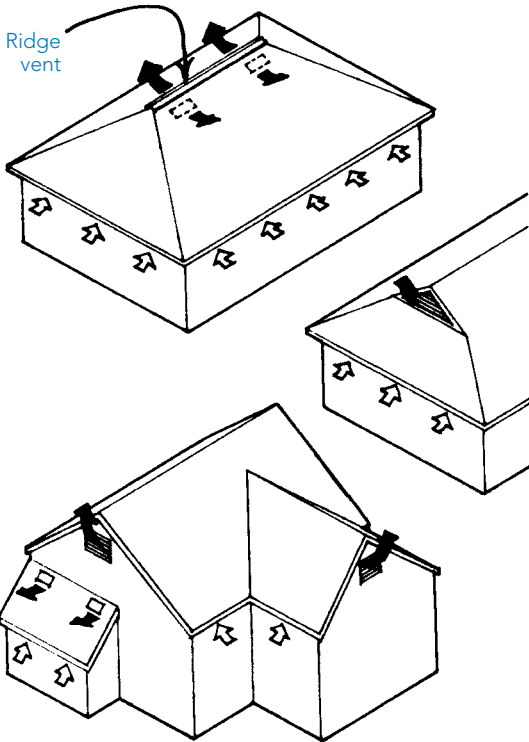
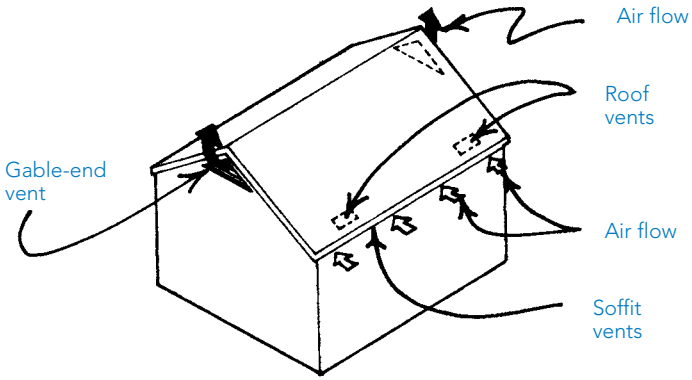

Some houses (especially older ones) will have been built so that no air can flow between the soffits and the attic space. In this case, roof vents located near the perimeter of the house can be substituted for soffit vents (see **Figure 11**).

Turbine or fan-powered attic vents are generally *not* recommended in our climate. Although these types of vents may keep an attic cooler in summer, the large amount of air they exhaust can create a negative pressure in the attic. During winter, this negative pressure may draw warm, moist air from the house and into the attic. If excessive, this moisture can damage the attic framing, insulation and ceiling finish.

If your home has limited attic space or a cathedral ceiling, ensuring adequate ventilation becomes much more difficult. In these cases, it is recommended that you discuss ventilation options with an insulation contractor and your local building authority.

Figure 12

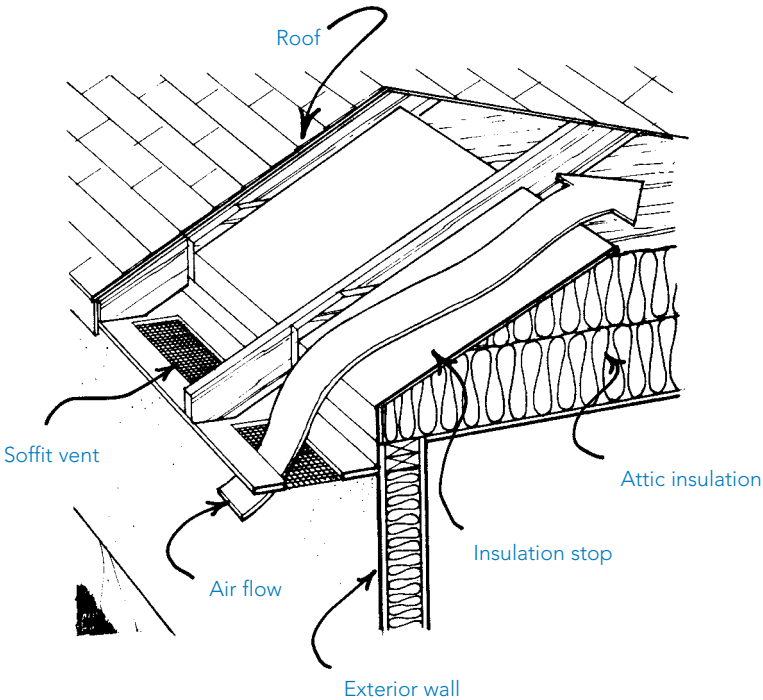

Insulating the Attic

After sealing potential sources of air leakage and ensuring adequate ventilation, the final step in retrofitting your attic is to add insulation.

The next few pages will help you to understand the techniques of adding insulation, whether you are doing the job yourself or just want to make sure the contractor you've hired is doing it properly.

Accessible Attics

The most common types of insulation material for use in an accessible attic space (refer back to **Figure 1** on page 3) are batt types (usually glass fibre) or loose fill insulation (usually cellulose or glass fibre). To choose the insulation type most appropriate to your situation, refer to **Table 1** — Insulation Summary (pages 30 to 37) for guidance.

In some circumstances it may be desirable to use a combination of insulation types (when compatible). If there are a lot of obstructions above the joists in the attic, it may be easiest to put batt insulation into the joist spaces and then use loose fill to create a complete blanket of insulation above the joists and around all the obstructions. On the other hand, if some loose fill already partially fills the joist spaces, or if the joist spaces are irregular or obstructed, it may be easiest to fill the joist spaces to the top with loose fill, and then add a layer of batt insulation crosswise on top of the joists.

Installing Batt Type Insulation:

If you choose to install batt type insulation, the following guidelines should be observed.

- Purchase the batts in a width to match the spacing of the attic framing.
- Open the bags containing the batts in the attic rather than in the house to reduce handling. The batts will significantly expand in size when released from the bags.
- The first layer of batts should be thick enough to completely fill the joist spaces. The second layer can then run in the opposite direction to completely cover the joists (see **Figure 13**).
- To prevent air movement from reducing the effectiveness of the insulation, ensure that there are no gaps between adjacent batts.

Figure 13

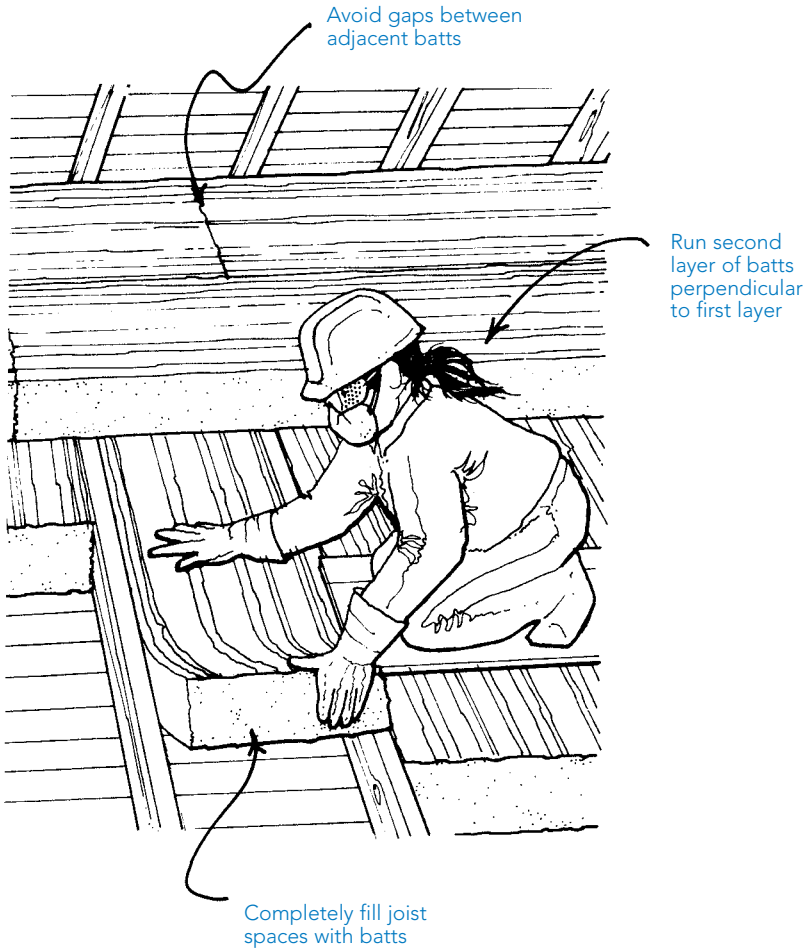

- Cut the batts with a utility knife and metal straightedge to the exact size required. Do not fold or compress the insulation to make it fit; this reduces the insulating value.
- Fill any awkward spaces or gaps with pieces of batts or with loose fill insulation.

Installing Loose Fill Insulation:

If you choose to install loose fill insulation, the following guidelines should be observed:

- Pour the loose fill insulation on top of the existing insulation. Level the insulation with a board or garden rake (see **Figure 14**).
- If the insulation is being added to a depth greater than the height of the joists, the extra thickness makes levelling a bit difficult but it will be worth it. Nail wood lath to the side of some of the joists to help you gauge the depth of the insulation. Maintain an even depth throughout the attic.

Figure 14

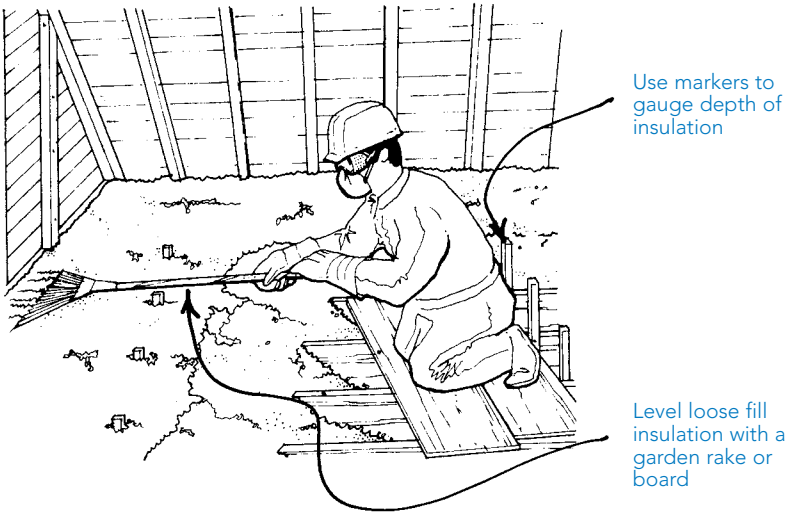

- If the loose fill insulation is deeper than the joists, build a crib around the attic hatch into the attic so that it can be filled to the edge (refer back to **Figure 9** on page 15).
- If you choose to use cellulose loose fill insulation, you may find it more convenient to blow in the insulation rather than pouring it. Blowing equipment can often be rented from your insulation supplier for a nominal charge. Make sure the supplier explains to you how to operate this equipment properly.

Additional Points When Insulating:

The following points are applicable whether you use batt or loose fill insulation:

- The insulation should extend as far as possible toward the eave. Caution must be taken to keep the insulation from blocking ventilation openings and/or falling into the eave space.
- Don't forget to insulate the hatch into your attic. Use glued-on rigid insulation or batt insulation held in place with cloth or burlap to an insulation level of at least RSI-3.5 (R-20) (refer back to **Figure 9** on page 15).
- Do not cover heat sources, such as exhaust fans, with insulation unless you are certain they are approved to be covered; the heat build-up may create a fire hazard.
- It is often difficult to properly seal and insulate around recessed light fixtures. Unless the fixture is labelled Type IC (insulation contact), covering it with insulation or sealing it to reduce air leakage may create a fire hazard. Consider replacing recessed light fixtures with lights that hang down in the room below. If you want the recessed light to remain, install a protective enclosure as shown in **Figure 15** or replace the fixture with an airtight Type IC unit.
- Leave a space between the insulation and the chimney to avoid creating a fire hazard (refer back to **Figures 10A** and **10B** on pages 16 and 17).

Figure 15

Minimum 12.5 mm (1/2 in.) clearance
– 150 mm (6 in.) preferred

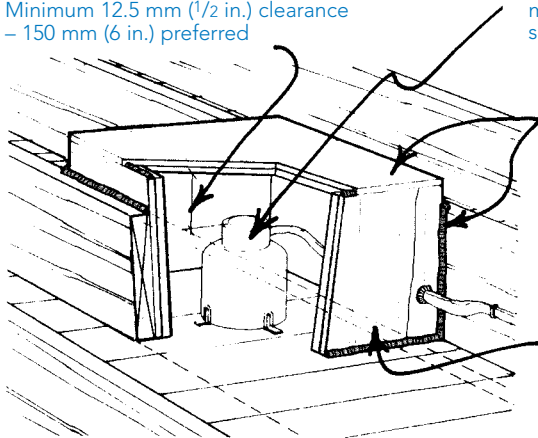

Centre fixture if possible – keep a minimum of 12.5 mm (1/2 in.) from sides

12.5 mm (1/2 in.) plywood box lined with fire-resistant material such as drywall or sheet metal to provide airspace around fixture (caulk all joints and edges of box to minimize air leakage)

Minimum box volume – allow 800 cubic centimetres per watt of fixture (e.g., a 150-watt fixture would require a 120,000 cubic centimetre box.)

Storey-and-a-Half Attics

This type of attic can be difficult to retrofit. Insulation is applied to the outer attic floor, walls and ceiling of the attic as shown in **Figure 16**.

Outer Attic Floor and Attic Ceiling:

- To prevent warm air from bypassing the insulation, block and seal the joist spaces under the kneewall with an impermeable rigid insulation and caulking (see **Figure 17**). If there are floor boards, temporarily remove them to gain access to this area.
- Seal and insulate the outer attic floor and attic ceiling as described for accessible attics on the previous pages.

Figure 16

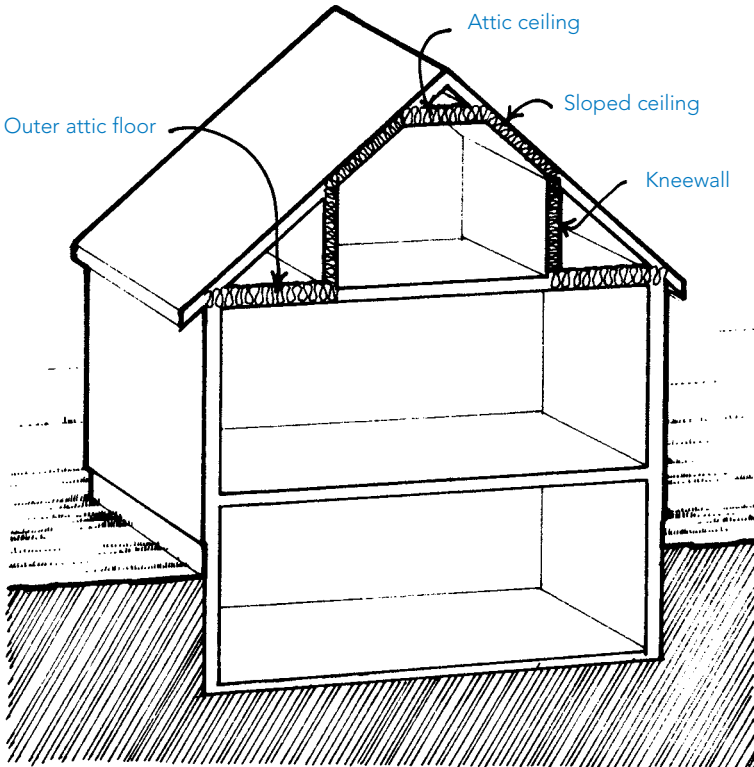
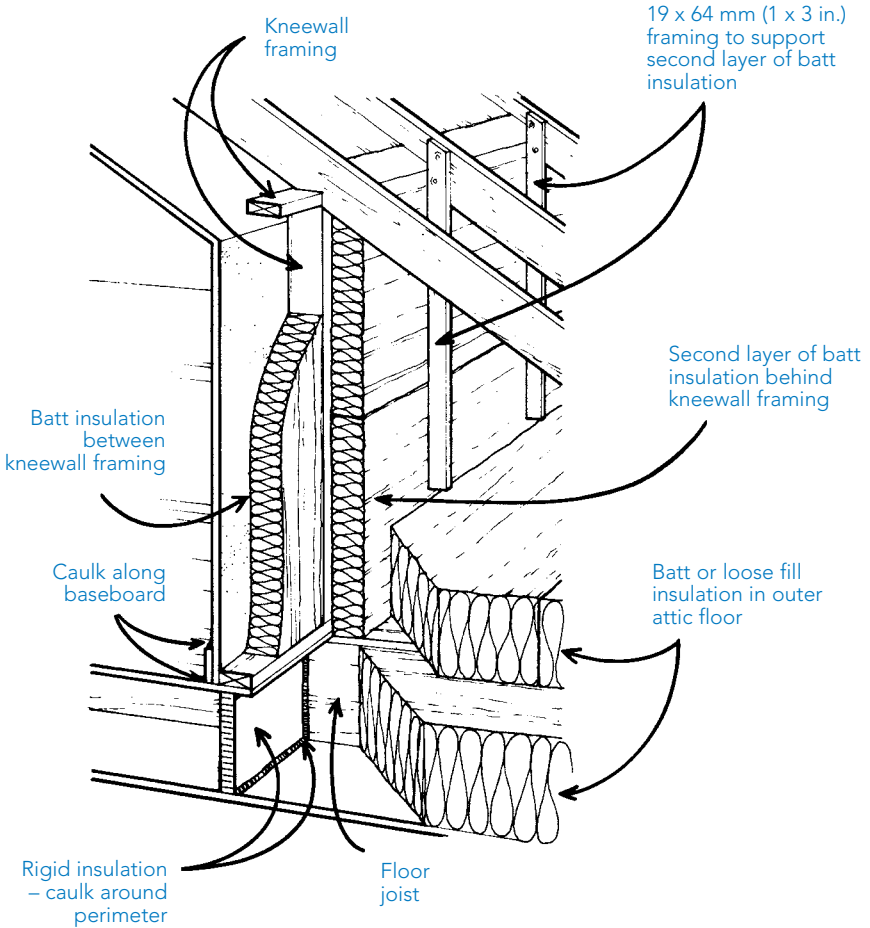

Figure 17



Kneewalls:

- Seal any obvious air leaks and then place batt insulation between the kneewall studs (see **Figure 17**).
- If the studs are 89 mm (3 1/2 in.) deep, use a single layer of RSI-2.1 (R-12) insulation vertically between the studs and another layer of RSI-3.5 (R-20) horizontally behind the studs. Support the second layer of insulation with 19 x 64 mm (1 x 3 in.) framing nailed to each rafter.

End Walls:

- The end walls can be insulated in several different ways; another publication in this series entitled *Wall Insulation (Booklet #4)* provides details.

Sloped Ceilings:

- Sloped sections of the ceiling can be strapped, insulated and covered with a new air-vapour barrier as shown in **Figure 18**. Two layers of strapping at right angles can be used to attain a higher level of insulation and to reduce “thermal bridges” through the wood strapping (wood has a lower resistance to heat flow than insulation).

Figure 18

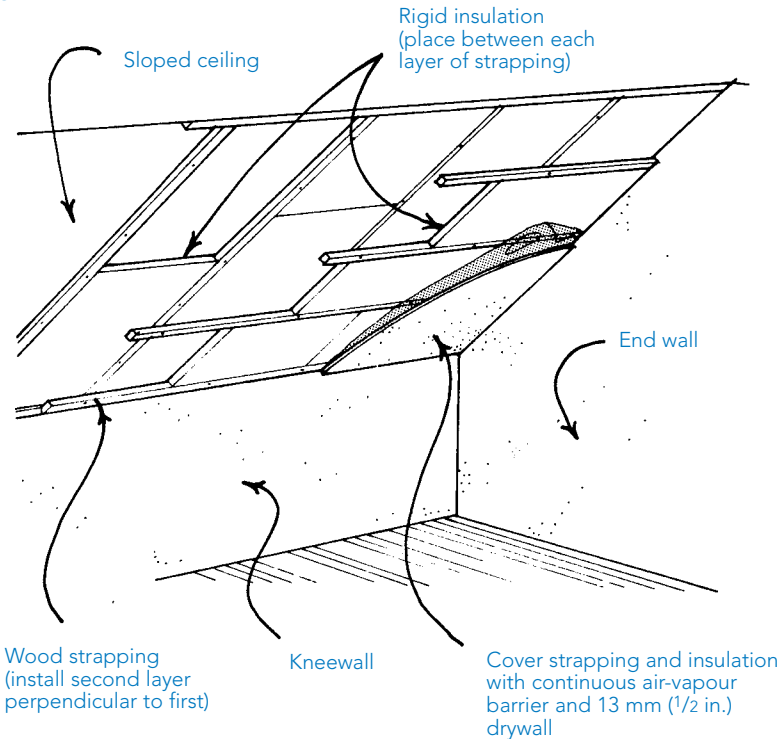

- With this method, the existing air-vapour barrier should be punctured 2 or 3 times between each rafter as a precautionary measure. This is necessary because the existing air-vapour barrier will now be on the cold side (in winter) of the new insulation.
- This method can also be used on the kneewalls and flat portion of the attic ceiling, if access to these areas is difficult.
- Remember that most rigid insulations are flammable and must be covered with a minimum of 13 mm (1/2 in.) gypsum wallboard.
- As an alternative, it may be possible to cut rigid pieces of insulation and then slide them into the rafter spaces (remember to leave a 25 mm (1 in.) space above the insulation to allow for ventilation). Since the rafters are often only 89 mm (3 1/2 in.) in depth, it is difficult to achieve much more than RSI-2.1 (R-12) without plugging the rafter spaces completely. This is below the recommended value for a ceiling but may be acceptable from a cost-effective standpoint.

Cathedral or Flat Ceilings

If your home has a cathedral ceiling or a flat roof, retrofitting will likely be both difficult and expensive. If there is already some insulation in the ceiling or on top of the roof, adding more will probably not be economical unless it is done in conjunction with general renovations or replacement of the ceiling or roof.

There are a number of retrofit techniques from which to choose; the following describes three different options. It is recommended that you contact a qualified professional to assist you in deciding which option is the most suited to your situation.

Insulate Below the Existing Ceiling:

- Insulation can be added to the underside of the ceiling as described for sloped ceilings in storey-and-a-half attics on the previous page (refer back to **Figure 18** on page 26).
- Make sure that the tops of interior partition walls do not allow air, containing both heat and moisture, to bypass the air-vapour barrier.

Insulate Above the Existing Roof

- If your home has an open beam ceiling which you would like to retain, it may be feasible to add insulation on top of the existing roof deck as shown in **Figure 19**.

Figure 19

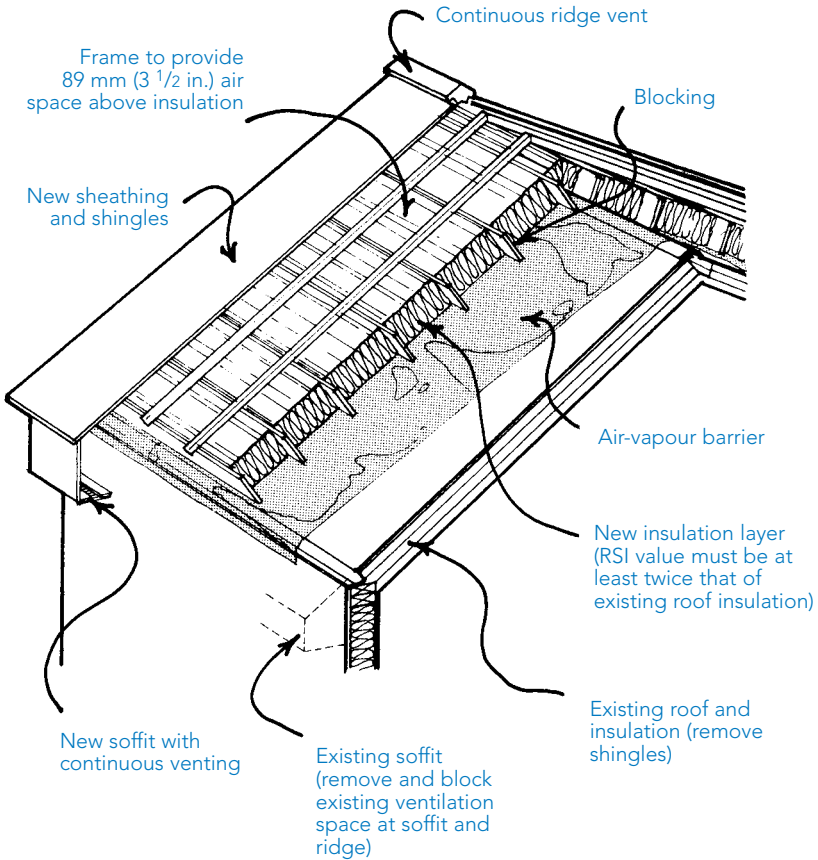

- The existing roof finish should be removed to allow for good contact between the insulation and the surface to which it is being applied. If the existing air-vapour barrier is not in good condition, a new one should be placed over the roof as shown.
- Any ventilation in the existing roof structure must be blocked. A new insulation layer with a RSI (R) value of at least *twice* that of the existing roof insulation can then be added. The new insulation can be either batt or rigid type.
- Adequate ventilation (usually continuous soffit and ridge vents) above the new insulation layer should be provided. The roof can then be sheathed and a new finish applied.

Build A New Peaked or Sloped Roof:

- It is sometimes possible to construct a new peaked or sloped roof over an existing flat roof as shown in **Figure 20**.
- Any ventilation in the existing flat roof is blocked and a new insulation layer is added as previously described.
- Consult a knowledgeable builder to determine the best way to tie the new rafters or trusses into the existing structure.

Figure 20

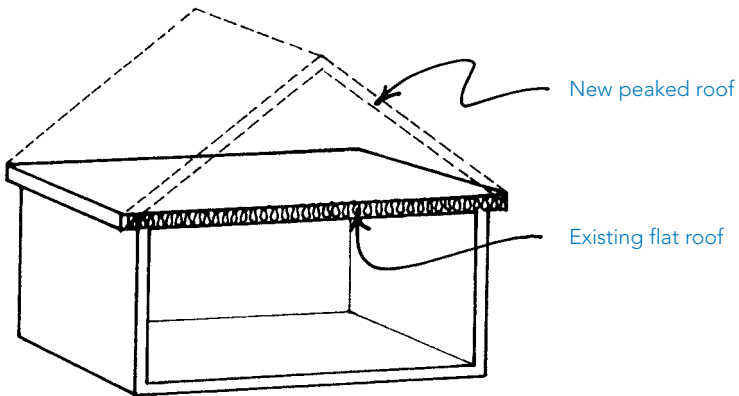

Table 1 — Insulation Summary

Material	RSI/100 mm	(R/in.)
Batt or Blanket Type Insulation		
<p>Glass Fibre</p> <ul style="list-style-type: none"> Composed of long fibres of spun glass loosely woven together and bonded with resin. Sizes available: <ul style="list-style-type: none"> Batt Length 1.22 m (4 ft.) Blanket Length up to 21.5 m (80 ft.) Width 381 or 400 mm (15 or 16 in.) 584 or 610 mm (23 or 24 in.) Thickness 76 to 304 mm (3 to 12 in.) 	2.2	(3.2)
Loose Fill Insulation		
<p>Cellulose Fibre</p> <ul style="list-style-type: none"> Manufactured from finely shredded newsprint with chemicals mixed in to resist fire and fungal growth. 	2.5	(3.6)
<p>Glass Fibre</p> <ul style="list-style-type: none"> Similar material to glass fibre batts but chopped up for blowing purposes. 	2.0	(2.9)
<p>Rock Wool</p> <ul style="list-style-type: none"> Made from natural rock which is melted, made into fibres and bonded. 	1.6	(2.3)

Advantages

- Easy to install in standard joist and stud spaces.
- Dries with little effect if exposed to moisture.
- Moderate cost.
- Some products are non-combustible; check with manufacturer.
- Lightweight.
- Non-settling.

Limitations

- Does not fit readily into uneven spaces.
- Can irritate the eyes, skin and respiratory system during installation.
- Little resistance to air leakage.

- Easily fills irregular spaces.
- Has a higher resistance to air leakage than most insulations.
- Is the only blown-in insulation that can be installed by a homeowner with rented equipment.
- Low cost.
- Recycles newspaper.

- Easily fills irregular spaces.
- Has a light weight for its RSI-value.
- Dries with little effect if exposed to moisture.
- Some products are non-combustible; check with manufacturer.
- Low cost.

- Easily fills irregular spaces.
- Highly resistant to fire.
- Dries with little effect if exposed to moisture.
- Low cost.

- Permanently damaged if exposed to excessive moisture.
- Should not be installed in contact with high-temperature sources (e.g. chimney, recessed lights, etc.)
- Should not be covered with heavier types of insulation which may compress it.
- Eye and respiratory system irritant during installation.
- May settle.

- Can irritate the eyes, skin and respiratory system during installation.
- Little resistance to air leakage.
- May settle.

- Adds considerable weight to attic — thick layers may compress existing insulation reducing its effectiveness.
- If the ceiling board is weak or moist, the additional weight may also cause sagging ceilings.
- Skin irritant during application.
- Little resistance to air leakage.
- May settle.

Material	RSI/100 mm	(R/in.)
Loose Fill Insulation (cont'd)		
Mineral Wool <ul style="list-style-type: none"> • Similar to rock wool except raw material is industrial slag. 	2.1	(3.0)
Vermiculite <ul style="list-style-type: none"> • Mica material that has been expanded by a high temperature steam process. 	1.6	(2.3)
Wood Shavings <ul style="list-style-type: none"> • By-product of wood industries. 	1.7	(2.5)

Advantages

- Same as rock wool.
- Easiest loose fill insulation to fill irregular spaces.
- Highly resistant to fire.
- Usually low cost if locally produced.
- Recycles wood waste.

Limitations

- Same as rock wool.
- High cost.
- Absorbs moisture and dries slowly.
- Adds considerable weight to attic — thick layers may compress existing insulation reducing its effectiveness.
- If the ceiling board is weak or moist, the additional weight may also cause sagging ceilings.
- May settle.
- Difficult to treat against fire, vermin and fungus growth.
- Absorbs moisture and dries slowly.
- Adds considerable weight to attic — thick layers may compress existing insulation reducing its effectiveness.
- If the ceiling board is weak or moist, the additional weight may also cause sagging ceilings.
- Should not be installed in contact with high-temperature sources. (e.g. chimney, recessed lights, etc.)
- May settle.

Material	RSI/100 mm	(R/in.)
Rigid Board Insulation		
Glass Fibre Board <ul style="list-style-type: none"> • Similar to glass fibre batts except formed into rigidboards. • Usually faced on one side with a material that is permeable to water vapour and impermeable to air movement. • Sizes available: <ul style="list-style-type: none"> Length 2.4 or 3 m (8 or 9 ft.) Width 1.2 m (4 ft.) Thickness 25 to 28 mm (1 to 1¹/₂ in.) 	2.9	(4.2)
Extruded Polystyrene <ul style="list-style-type: none"> • A foam plastic board composed of fine, closed cells containing a mixture of air and refrigerant gases (fluorocarbons). • Sizes available: <ul style="list-style-type: none"> Length 1.2 or 2.4 m (4 or 8 ft.) Width 406 or 610 mm (16 or 24 in.) Thickness 25, 38, 51 or 78 mm (1, 1¹/₂, 2 or 3 in.) 	3.5	(5.0)
Expanded Polystyrene (“Beadboard”) <ul style="list-style-type: none"> • Produced by a process that results in coarse, closed cells or beads containing air, bonded together into rigid, foam plastic boards. • Sizes available: <ul style="list-style-type: none"> Length 1.2, 2.4 or 2.7 m (4, 8 or 9 ft.) Width 406, 610 or 1220 mm (16, 24 or 48 in.) Thickness 19 to 152 mm (3/4 to 6 in.) 	Low Density 2.5 High Density 2.8	(3.6) (4.0)

Advantages

- Easy to handle and install.
 - Some products are non-combustible; check with manufacturer.
 - High RSI-value per unit thickness.
-
- Most moisture resistant rigid board insulation.
 - Easy to handle and install.
 - Can perform as an air-vapour barrier when installed on interior side of insulated cavities if joints are sealed properly.
 - High RSI-value per unit thickness.
-
- Lowest cost per RSI-value of all the rigid insulation boards.
 - Easy to handle and install.

Limitations

- High cost.
 - More compressible than other rigid board insulations.
 - Skin irritant during installation.
 - Tedious to fit an irregular space.
-
- High cost.
 - Can be a fire hazard unless properly covered.
 - Must be protected from exposure to sunlight or solvents.
 - Tedious to fit in an irregular space.
-
- Can be a fire hazard unless properly covered.
 - Must be protected from exposure to sunlight or solvents.
 - Tedious to fit in an irregular space.

Material	RSI/100 mm	(R/in.)
Rigid Board Insulation (con't)		
Polyurethane Boards <ul style="list-style-type: none"> • A foam plastic board with primarily closed cells filled with refrigerant gases (fluorocarbons). • Usually foil-faced on both sides to strengthen the board and retain the gases which give it a high RSI-value • Sizes available: <ul style="list-style-type: none"> Length 2.4 m (8 ft.) Width 1.2 m (4 ft.) Thickness 25, 38 or 51 mm (1, 1¹/₂ or 2 in.) 	4.2	(6.0)

Advantages

- Highest RSI-value per unit thickness of all rigid insulation boards.
- Easy to handle and install.
- Can perform as an air-vapour barrier when installed on interior side of insulated cavities if joints are sealed properly.

Limitations

- Very high cost.
- Can be a fire hazard unless properly covered.
- Must be protected from exposure to sunlight or solvents.
- Loses some thermal resistance as it ages.
- Tedious to fit in an irregular space.

**Table 2 — Ventilation Requirements
— Vent Area to Ceiling Area Ratio**

Type of vent covering	Ceiling with a polyethylene air-vapour barrier (or equivalent)		Ceiling without a polyethylene air-vapour barrier (or equivalent) Any slope
	Normal or steep slope roof (1-in-3 or more)	Low slope roof (Less than 1-in-3)	
Unobstructed Opening	1:300	1:150	1:150
Screened Opening 3 mm (1/8 in.) 1.5 mm (1/16 in.)	1:270	1:135	1:135
	1:220	1:110	1:110
Screened and Louvered opening 3 mm (1/8 in.) 1.5 mm (1/16 in.)	1:220	1:110	1:110
	1:200	1:100	1:100

Example 1 — A home with a polyethylene air-vapour barrier, 112 square metres (1200 square feet) of ceiling area and normal slope roof would require $(112/270)$ 0.41 square metres (4.4 square feet) of 3 mm (1/8 in.) **Screened Vent**.

Example 2 — A 84 square metre (900 square foot) home with no air-vapour barrier would require $(84/110)$ 0.76 square metres (8.2 square feet) of 3 mm (1/8 in.) **Screened, Louvered Vent**.

Metric Conversion Factors

A. Converting Imperial Units into Metric Units

Unit	Conversion	Multiply By
Thermal Resistance	R values to RSI values	0.1761
Length	inches to millimetres	25.40
	inches to centimetres	2.540
	feet to metres	0.3048
Area	square feet to square metres	0.09290
Volume	gallons to litres	4.546
	cubic feet to cubic metres	0.02832
Mass	pounds to kilograms	0.4536
Density	pounds/cubic feet to kilograms/cubic metre	16.02

B. Converting Metric Units into Imperial Units

Unit	Conversion	Multiply By
Thermal Resistance	RSI values to R values	5.678
Length	millimetres to inches	0.03937
	centimetres to inches	0.3937
	metres to feet	3.281
Area	square metres to square feet	10.76
Volume	litres to gallons	0.2200
	cubic metres to cubic feet	35.31
Mass	kilograms to pounds	2.205
Density	kilograms/cubic metre to pounds/cubic foot	0.06243

If you are uncertain of, or have any question or concern regarding, any subject matter herein or the safety and/or proper handling of any material(s) and/or product(s) that you may encounter in your undertaking, please consult resources such as Health Canada (Health Links) @ 1-888-315-9257, the Manitoba Department of Labour @ 1-800-282-8069, or CMHC (Canada Mortgage & Housing Corp.) @ 1-800-668-2642.

The information contained herein is published as a convenient reference for Manitoba Hydro's customers. While every effort has been made to provide accurate and complete information, Manitoba Hydro does not warrant the accuracy or efficacy thereof. Manitoba Hydro will not be liable for any loss, costs, damage or injury whatsoever, resulting from the use of this material.

Cette information est également disponible en français.

