

4

POWER SMART GUIDE:
Energy saving solutions for home comfort

Wall insulation



 **Manitoba
Hydro**
POWER SMART

*Manitoba Hydro is a licensee of the Trademark and Official Mark.

For more information on Power Smart:

Telephone: (204) 480-5900 in Winnipeg

Toll-Free: 1 888 MBHYDRO (1-888-624-9376)

Or visit www.hydro.mb.ca

Publications in this series

- ① Sealing, Caulking & Weatherstripping
- ② Basement & Crawlspace Insulation
- ③ Attic Insulation
- ④ Wall Insulation
- ⑤ Doors & Windows
- ⑥ Heating Systems
- ⑦ Water Heaters
- ⑧ Indoor Air Quality & Ventilation
- ⑨ Low Cost No Cost Energy Savings Tips



BOOKLET #4

Wall Insulation

Contents

Introduction

Why Retrofit?	1
Do-It-Yourself or Hire A Contractor	1

Checking your Walls

Precautions Before Starting	2
How to Inspect Your Walls	3
• Determining Insulation Values	3
• Locating Air Leaks	5
• Checking for Moisture Problems	8

Retrofit Techniques

Sealing Air Leaks	9
Insulating Empty Wall Cavities	12
• Poured Insulation	13
• Blown-in Insulation	13
• Foamed-in-Place Insulation	17
Renovating Insulated Walls	17
• Insulating from the Inside	18
• Insulating from the Outside	20
Table 1 - Insulation Summary	24

Introduction

Why Retrofit?

Save Money — Heating a home, especially in our climate, can be expensive. Exterior walls that are poorly insulated can add significantly to your heating bill. Although it can be expensive, retrofitting your home’s exterior walls can be a good long-term investment. This is especially true if you combine the retrofit with other renovations such as residing.

Increase Comfort — A well-insulated house is a comfortable house. A thorough exterior wall retrofit will reduce uncomfortable winter-time drafts. Often, it will also help you to achieve an even temperature throughout your home.

Conserve Energy — Approximately 13% of Manitoba’s annual energy use goes to heat our homes. Much of that energy can and should be saved. Retrofitting your home will help save our valuable energy resources at a cost lower than producing new energy supplies.

In addition to these major benefits, a well-planned exterior wall retrofit may improve the appearance and value of your home. The retrofit may also reduce or eliminate moisture-related problems such as condensation or mold and mildew on the inside surface of cold exterior walls.

Do-It-Yourself or Hire A Contractor

Since exterior wall retrofits are a major undertaking, and mistakes are highly visible, it is recommended that this work be undertaken only by experienced “do-it-yourselfers” or a contractor.

If you choose to do the work yourself, the savings and job satisfaction can be high. Please read this booklet carefully. For additional information, please contact us (see inside front cover), or your local building material supplier.

If you intend to have a contractor do some or all of the work, this booklet will still be of interest to you. You are likely to get the results you want if you are knowledgeable about the work and take an active interest in what the contractor does. For further information on how to hire a contractor, call the Consumers’ Bureau at 945-3800 (Winnipeg), toll-free at 1-800-782-0067 or e-mail consumersbureau@gov.mb.ca.

Whether you do-it yourself or hire a contractor, please remember that this booklet does not describe every possible technique for retrofitting a wall. *Each home is unique, and you or your contractor may find it necessary or desirable to modify the techniques shown in this booklet.*

Checking Your Walls

Precautions Before Starting

The techniques discussed in this booklet are for wood frame walls, the most common type in Manitoba homes (see **Figure 1**). Your house may have a stone or brick veneer over wood frame walls. In these cases, this booklet is still for you.

If your home has *solid* stone, brick or wood walls, special techniques not covered by this booklet may be required. Obtain advice from a professional with experience with these types of construction.

Before you tackle the job of checking and retrofitting your walls, make sure you are familiar with the following safe working procedures:

- Locate electrical wiring in the walls, and then avoid all unnecessary contact with it. If it doesn't look safe (e.g. cracked covering, bare wires, open junction boxes) have it inspected by a qualified electrician.
- Use ladders correctly; support them properly and have a helper steady them.
- Provide good lighting.
- Wear goggles when using a circular saw, drill or hammer, or if there is a possibility of particles coming in contact with the eyes.
- Wear a dust mask.
- Wear gloves and thick, loose clothing with long sleeves and tight cuffs to minimize skin irritations when handling insulation.
- A hard hat can be worn to keep insulation particles out of your hair and to prevent head injuries.
- If available, wear safety boots. Otherwise wear shoes with good traction.
- Most rigid insulations are very flammable and should be kept well away from sources of heat. If used indoors, cover any exposed rigid insulation with 13 mm (1/2 in.) gypsum wallboard or equivalent.
- Kraft paper facing on insulation batts and polyethylene air-vapour barriers are also fire hazards and should not be left exposed.
- When cleaning up insulation fibres or dust, use a vacuum cleaner. If you can only sweep-up the material, dampen it first to prevent particles from becoming airborne.
- After the work is complete, vacuum your work clothes and then wash them separately from other clothing.

Figure 1

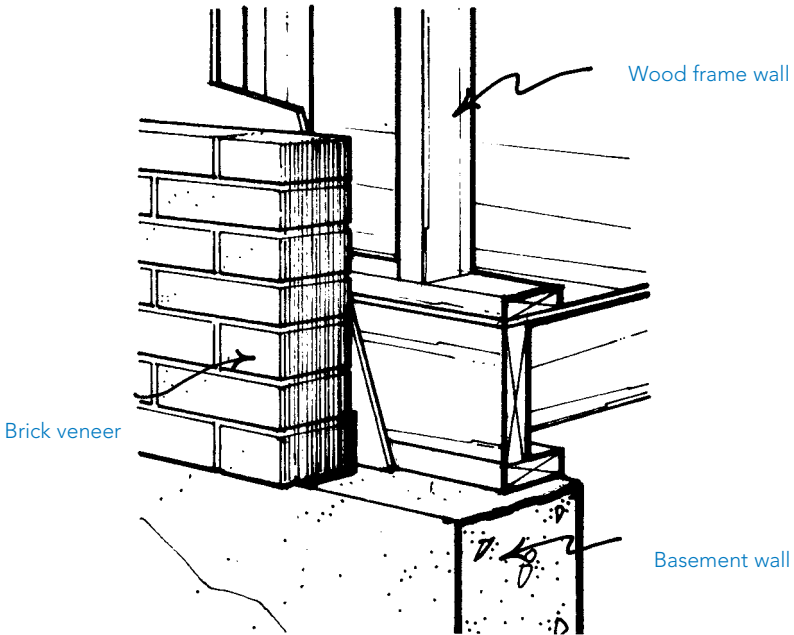

How to Inspect Your Walls

The first step is to determine the existing condition of your home's exterior walls. A good understanding of what shape the walls are in is essential in planning what has to be done, and in choosing the best materials or selecting the proper contractor.

You'll need to determine the type, amount and condition of any existing insulation. You will also have to assess whether the walls are sealed adequately against air leaks (drafts) and if they have a moisture problem.

The next few pages describe how to inspect your walls to determine your retrofitting needs.

Determining Insulation Values

There are several ways of finding out the amount and type of insulation in the exterior walls:

- It may be possible to see into the wall space by removing a cover plate at a light switch or outlet box (*be sure to turn the power off first*). Use a bent wire or crochet hook to pull out a sample of insulation and gauge the depth of the wall cavity (see **Figure 2**).
- In some houses (especially older ones), the wall space may be visible from the attic space.
- In some houses, you can drill upwards into the wall space from the basement. (Don't forget to plug the hole after you have finished your inspection.)
- It may be necessary to drill a small hole into the wall in a closet or some other out-of-sight location. The hole could also be drilled from the outside, if the walls are to be refinished anyway. In either event, patch the hole as soon as possible.

Figure 2

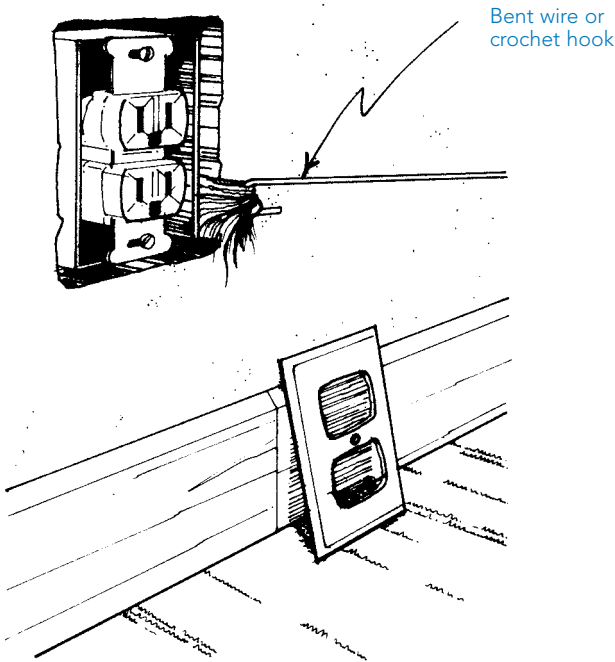

In some homes, the amount and type of insulation may not be the same in all the exterior walls. This is often the case in homes that have had an unheated porch converted into heated living space or an addition. If you suspect that there may be a variation in the amount and type of insulation present, explore the wall spaces in a least two or three different locations.

Calculate the value of the insulation using the RSI-value (R-value) shown in **Table 1** (on page 24). If you have trouble identifying the insulation type, take a small sample to a local building supply outlet for help.

If you suspect that your home has been insulated with urea formaldehyde foam insulation (UFFI), consult a professional to verify its presence. (UFFI can be easily crumbled with the fingers and does not bounce back when an object is lightly pressed into it. It is usually white or cream coloured or, in some cases, blue).

Many homeowners with UFFI decide to implement some form of corrective measure (usually removal of the UFFI). This is because some people exposed to UFFI gas and particles experience health problems and also because the resale value of a UFFI-insulated home is often adversely affected. For additional information on how to identify UFFI, its health effects or corrective measures, contact Canada Mortgage and Housing Corporation at 983-5600.

If your inspection reveals that the walls do not contain any insulation, a practical, cost-effective solution is to fill the wall cavities with insulation by pouring or blowing it in, as described on pages 12 to 17.

If the walls are partially or fully filled with insulation, adding more will be costly and the payback (in terms of energy savings) lengthy. However if you plan major interior renovations or if you intend to refinish the exterior of your home anyway, adding more insulation at the same time can be a good long-term investment. Techniques for this type of situation are described on pages 17 to 23.

Locating Air Leaks

Check for sources of air leaks in the exterior walls so that you can seal them before insulating. Excessive air leakage not only adds to your heating bills but can also carry significant amounts of moisture into the walls where it can damage the insulation and framing. *To insulate the walls without first sealing air leaks may defeat the purpose of the insulation, and unnecessarily expose the house to a higher risk of moisture damage.*

It is worth investigating the possibility of air leaks in exterior walls at the following locations (see **Figure 3**):

- Around door and window trim.
- Around electrical switches and outlets on outside walls.
- At the junction of the floor and exterior wall.
- Along cracks in the wall finish.

Figure 3 • Typical air leakage paths in exterior walls

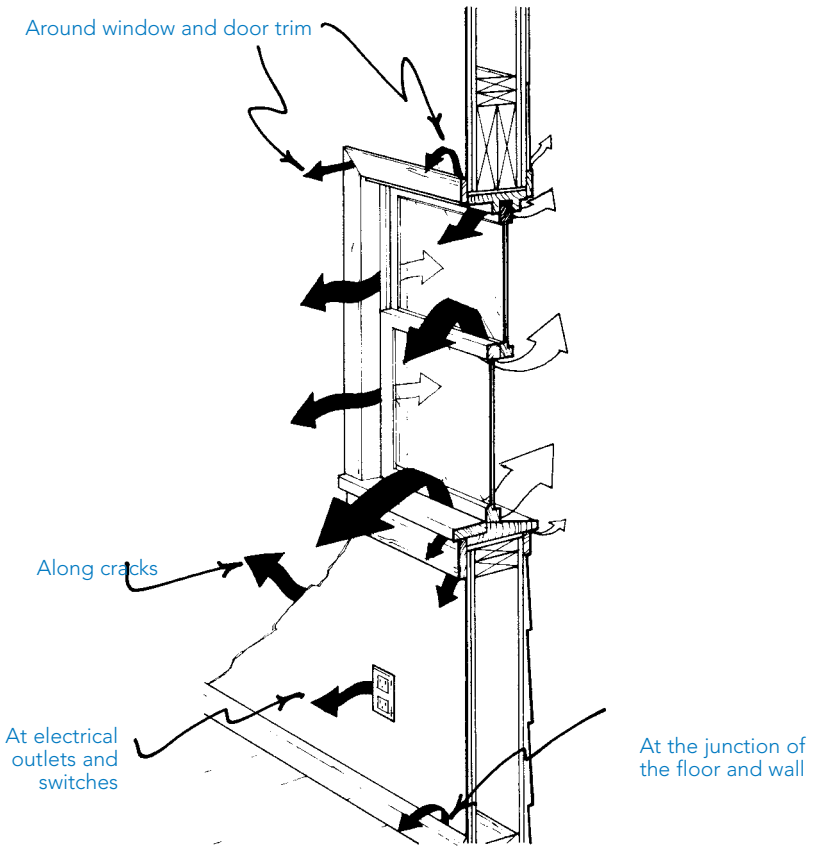

One way to detect air leaks is to make a *draft detector*, as shown in **Figure 4**. Hold the detector steady next to a suspected source of air leakage. If there is a draft, the plastic or tissue will flutter.

As an alternative, you may prefer to use the smoke from an incense stick as your indicator.

It is easier to locate air leaks on cold and windy days. Turn down your thermostat to prevent the furnace fan from affecting the test. You can also intensify the air leaks by turning on any exhaust fans or appliances (e.g. central vacuum) that are vented to the outdoors.

Methods for sealing air leaks are described on pages 9 to 12.

Figure 4

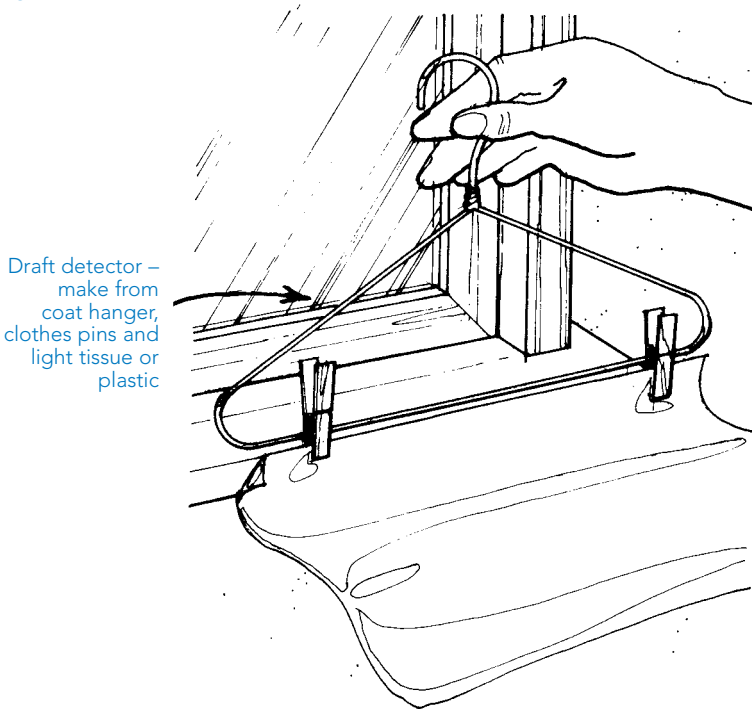

Checking for Moisture Problems

Examine the exterior walls for moisture-related damage from both inside and outside the house. *It is important that any damage be repaired and the cause of damage eliminated before adding insulation to the walls.*

Examples of moisture related damage to exterior walls include:

- Stains on drywall or plaster.
- Mold or mildew (especially in corners).
- Damp or wet insulation.
- Damp or rotten wood framing members.
- Corroded electrical boxes.
- Peeling or blistering paint.
- Rotten wall sheathing or siding.

As noted previously, excessive air leakage is a common source of moisture related damage in exterior walls. Methods for reducing air leaks are described on pages 9 to 12.

Excessive humidity levels in the home during winter can also contribute to moisture damage in walls. Other possible sources of moisture damage in exterior walls which should be corrected prior to insulating includes:

- Faulty roofing.
- Improper flashing at the top of door or window openings.
- Gaps around the exterior trim of doors, windows, or other penetrations of the home's exterior shell.

Retrofit Techniques

Sealing Air Leaks

Before adding any insulation, seal as many potential sources of air leakage as possible. It is important to spend a little extra time and be thorough when doing this work. As previously described, excessive air leakage not only adds to your heating bills but can also carry significant amounts of moisture into the exterior walls where it may damage the insulation and framing

Methods of sealing common sources of air leakage are listed below and illustrated in **Figures 5 to 9** (on pages 9 to 12). Another publication in this series entitled *Sealing, Caulking and Weatherstripping* (Booklet #1) provides additional information on the types and applications of caulking and weatherstripping materials

- **Door and Window Trim** — Run a continuous bead of clear or paintable caulk along the gap between the trim and wall, as shown in **Figure 5**. Similarly, run a bead along any gap between the trim and window frame and the trim mitre joints.

Figure 5

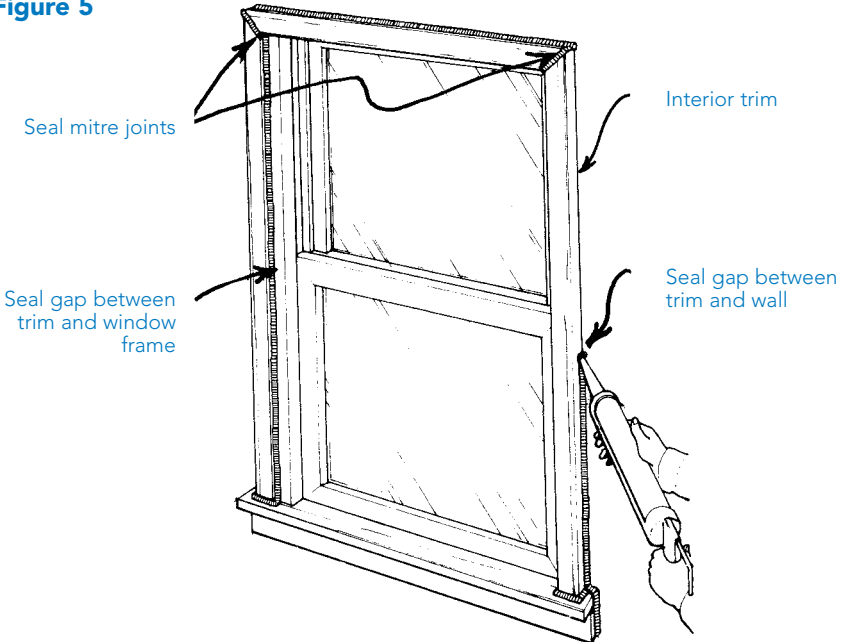

It is also possible to seal *behind* the trim, if the previous technique is unacceptable on aesthetic grounds. Carefully remove the trim and caulk the gap. Large gaps can be filled with insulation and sealed with strips of 0.15 mm (6-mil) polyethylene attached with acoustical or butyl rubber caulking and staples as shown in **Figure 6**. Alternatively, seal the gap with foam insulation from an aerosol container (take care to allow for expansion of the foam and trim the excess foam, if necessary).

Figure 6

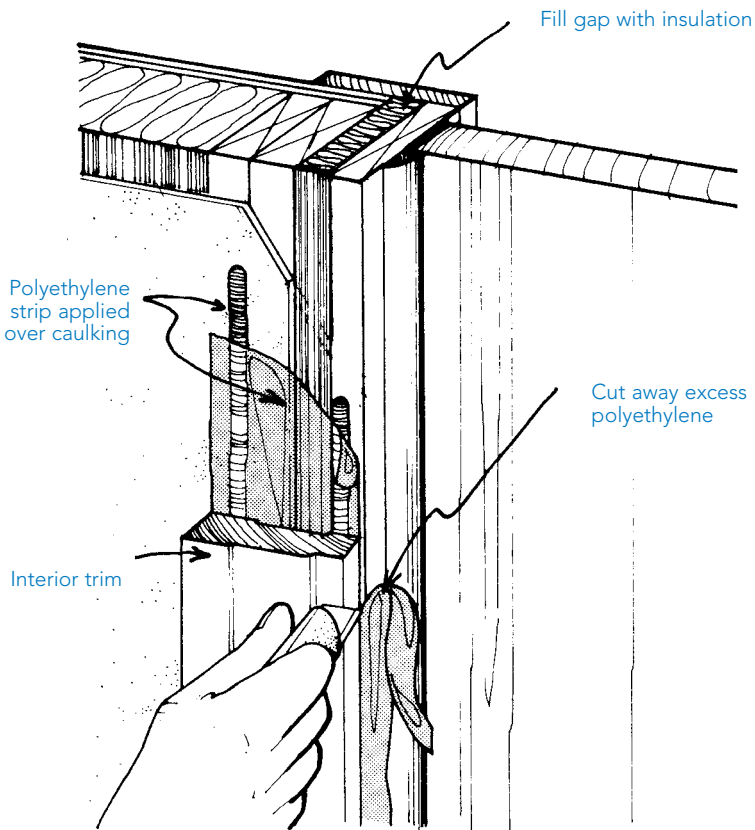

- **Junction of Floor and Exterior Walls** — Run a continuous bead of clear or paintable caulk along the gap between the baseboard and wall, baseboard and base mould, and the base mould and floor, as shown in **Figure 7**.

Figure 7

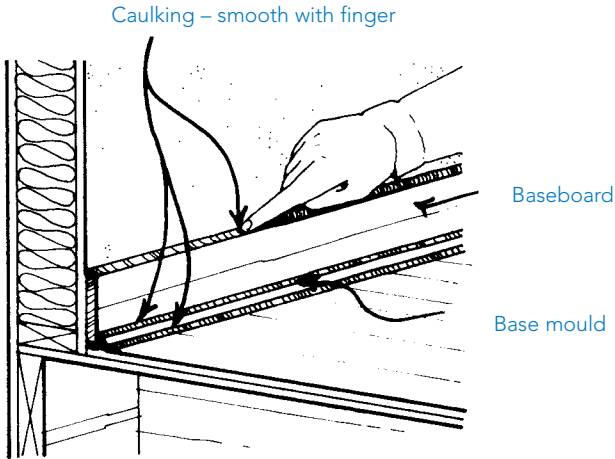

If exposed sealant along the baseboard is unacceptable, consider sealing *behind* the baseboard and base mould. Use foam insulation from an aerosol container, as shown in **Figure 8**. Be careful to limit the amount of foam used, since it expands (trim the excess foam, if necessary).

Figure 8

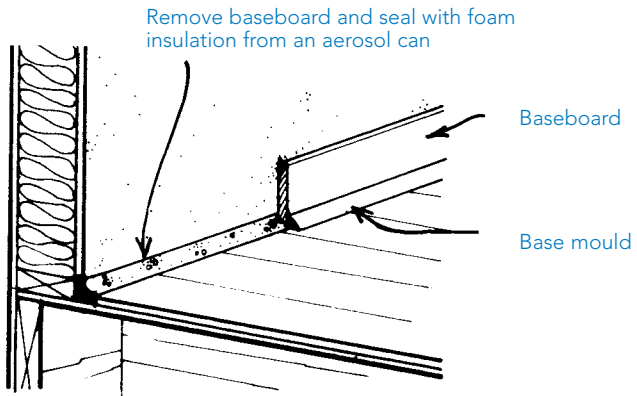

- **Electrical Switches and Outlets** — Switch off the electricity and remove the cover plates from switches and outlets. Place a *CSA-approved* foam gasket on the receptacle, as shown in **Figure 9**. Reinstall the cover plate and insert childproof plugs in little-used outlets to further reduce air leakage.
- **Cracks in the Wall Finish** — Use a sharp tool to open up the crack into a small ‘V’-shaped indentation. Fill and sand the crack using standard drywalling procedures.

Figure 9

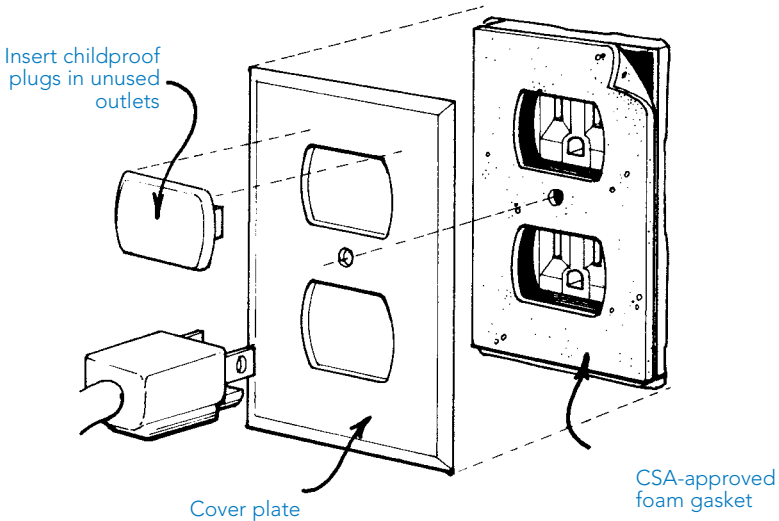

Insulating Empty Wall Cavities

After sealing potential sources of air leakage and dealing with any moisture problems, the final step in retrofitting your home’s exterior walls is to add insulation.

As previously mentioned, if an inspection of the walls reveals that they do not contain any insulation, a practical and cost-effective solution is to fill the wall cavities with poured or blown-in insulation, as described on the next few pages.

Although it is also possible to fill a wall cavity with foamed-in-place insulation, this method is *not* recommended (please refer to page 17).

Poured Insulation

If your home has wall spaces which open into the attic, you may be able to pour insulation into each wall cavity. Make sure that each wall cavity is continuous down to the foundation (check them with a weight on a string). Also check that there are no openings at the base of each wall cavity which would allow the insulation to escape into the basement.

When using poured insulation, consider the following points:

- Specially coated (water-resistant) vermiculite does the best job of filling irregular cavities. Cellulose, glass fiber, rock wool or mineral wool loose fill insulation are also acceptable if care is taken to ensure all portions of the cavities are filled. For a description of the advantages and limitations of each type of insulation, refer to **Table 1** (on page 24).
- Windows or other obstructions may prevent the entire wall cavity from being filled. In these cases, consider having a contractor blow insulation into wall spaces not accessibly by pouring.
- Any partial obstructions in a wall cavity (wires, pipes, etc.) can prevent the insulation from completely filling the cavity. “Jam-ups” around these barriers can generally be loosened by pounding on the inside of the wall at the appropriate point.
- Some settling of the insulation may occur after pouring. Go back into the attic a few months after insulating and re-fill the wall cavities to the top if necessary. A bulky, heavy object tied to a rope may be used for filling and moderate packing of the insulation to minimize any future settling.

Blown-In Insulation

If your home does not have wall spaces which open into the attic, loose fill insulation can be blown in. Since this requires special equipment, you will have to hire an insulation contractor.

Choose a contractor carefully; you won't get a worthwhile return on your money if your contractor cuts corners. Choose the insulation in consultation with the contractor. Refer to **Table 1** (on page 24) for the relative merits of the various types of loose fill insulations.

When you have selected an insulation, calculate the number of bags required and have the contractor write this information into your contract (the coverage will be indicated on the bags of insulation - make sure the information used is for wall applications and *not* attics).

Only a small variation from this target is acceptable. If the contractor uses too little, the insulation will not completely fill the wall cavities or it may be prone to excessive settlement. If too much is used, some of the insulation may be wasted by escaping from the wall into a floor space or other area where it is not needed.

An access hole must be drilled by the contractor into each stud space in the walls. In most cases, two or more holes must be drilled not more than 1.2m (4 ft.) apart. There are four possible ways of doing this:

1. From the outside — Stucco or siding can have holes of 15mm to 50mm ($\frac{5}{8}$ to 2 in.) diameter drilled to permit access to the wall cavities (see **Figure 10**). With some homes, it may be possible to remove a few rows of siding temporarily and then drill through the wall sheathing. In homes with brick facing, it may be possible to have single bricks removed or holes drilled through the mortar between the bricks.

Insulation can then be blown through these holes directly into the wall cavities. With brick facing, insulation should *not* be allowed to enter the drainage cavity between the brick and stud walls.

Ensure that the contractor patches the holes soon after insulating as a precaution against water damage from a sudden rainstorm. *A poor patch job can seriously detract from the appearance of your home; make sure your contract states that the holes are to be sealed, patched, and then finished in a manner identical to the existing exterior finish of your home.*

2. From the inside — This method may be appropriate if the exterior finish is in good condition but the interior requires decoration or renovation. Holes are drilled through the interior wall finish and insulation blown directly into the wall cavities.

Since this method will perforate any existing air-vapour barrier, it is necessary to seal the holes soon after the job is done. In cases where the interior finish is in very poor condition, it may be desirable to drill the holes, blow in insulation, install a well-sealed 0.15mm (6 mil) polyethylene air-vapour barrier over the old interior wall, and apply new drywall (see **Figure 11** on page 16).

3. From the basement — if the bottom of the exterior wall is accessible, this can be the most appropriate method to use. It is also more practical than the previous two methods if both the interior and exterior wall finishes are in good condition.

A long hose is inserted to within 150mm (6 in.) of the top of the stud space. The hose is then withdrawn, 300mm (12 in.) at a time.

Figure 10

Siding temporarily removed to allow holes to be drilled

Insulation blown-in holes drilled into each stud space

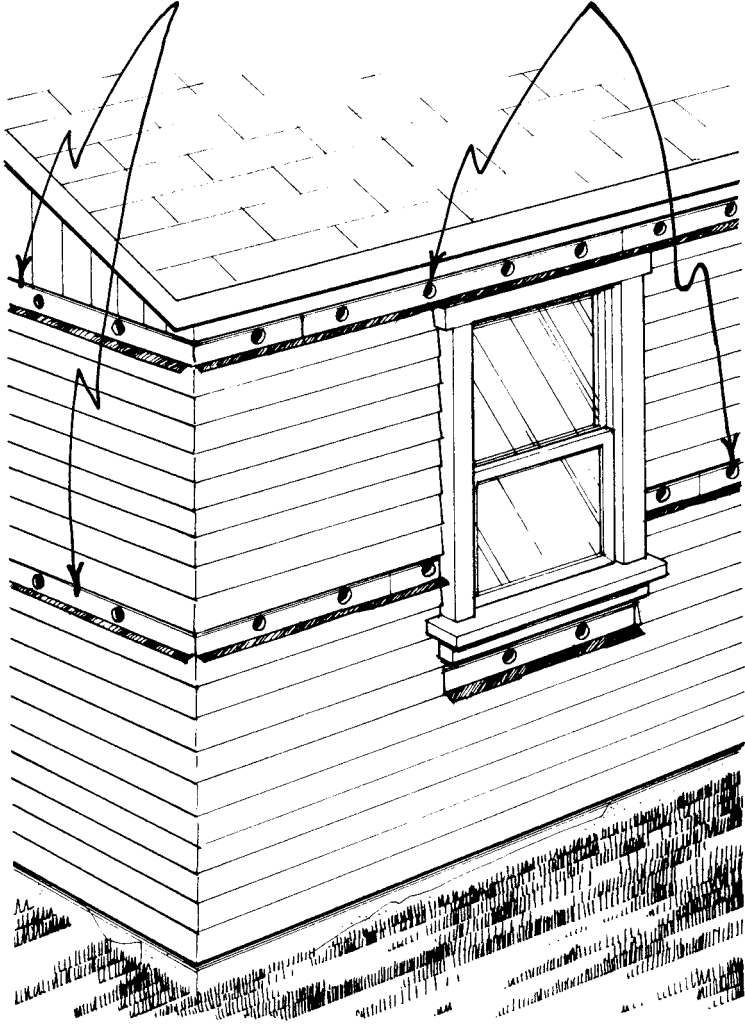
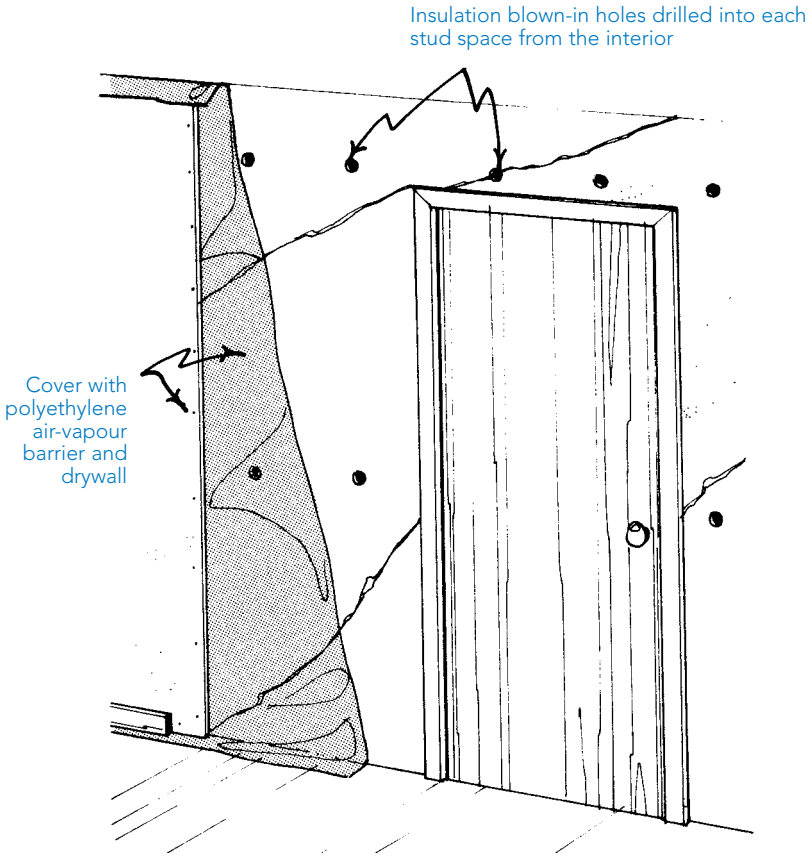

Figure 11



At each stage, the space above the hose is allowed to completely fill with insulation (see **Figure 12**).

All spaces in the wall should be filled. Firebreaks, windows, and other obstructions may necessitate insulating portions of the wall through holes drilled in the outside or inside faces of the wall.

- 4. From the attic** — Holes can be drilled in the top plates of the exterior walls. In a manner similar to the previous method, a hose is inserted down into the wall and then withdrawn 300mm (12 in.) at a time as the space fills.

Figure 12

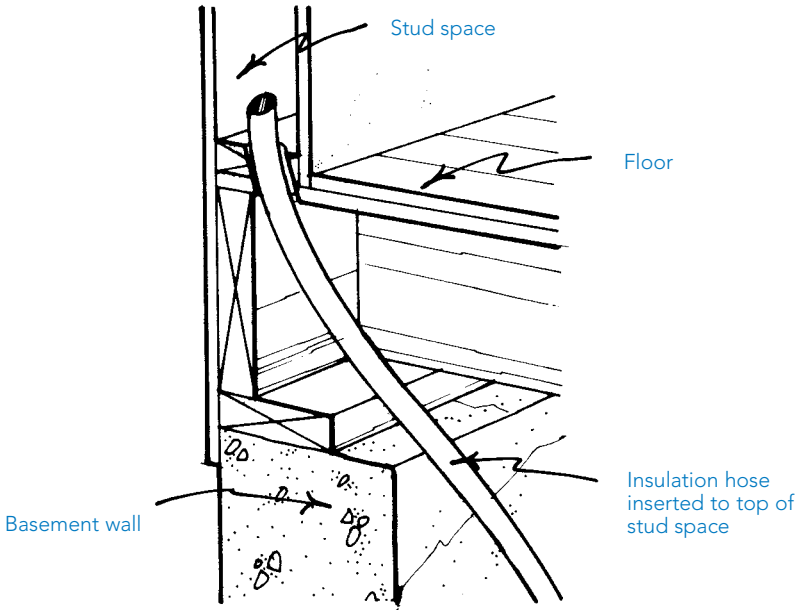

Foamed-In-Place Insulation

There is currently no accepted material available in Manitoba for use in homes that, when injected into a wall cavity as semi-liquid foam, will quickly solidify to give a solid, permanent and problem-free insulation material.

Renovating Insulated Walls

As previously described, if the walls are already partially or fully filled with insulation, adding more will be costly and the payback (in terms of energy savings) lengthy. However, if you plan major interior renovations or if you intend to refinish the exterior of your home anyway, adding more insulation at the same time can be a good long term investment.

Various methods of adding insulation to the interior or exterior of existing walls are described on the next several pages.

Insulating From The Inside

If your plans include extensive interior renovations, consider the following two options:

1. Rebuild the existing wall

- Remove the baseboards and trim around doors and windows.
- Strip the existing drywall or plaster and air-vapour barrier.
- Replace any wood framing that has been damaged by moisture.
- Add insulation to wall cavities if the existing insulation does not completely fill the spaces (do not fold or compress the insulation to make it fit; this reduces the insulation value).
- Add 38 x 38mm (1 1/2 x 1 1/2 in.) horizontal furring as shown in **Figure 13**.

Figure 13

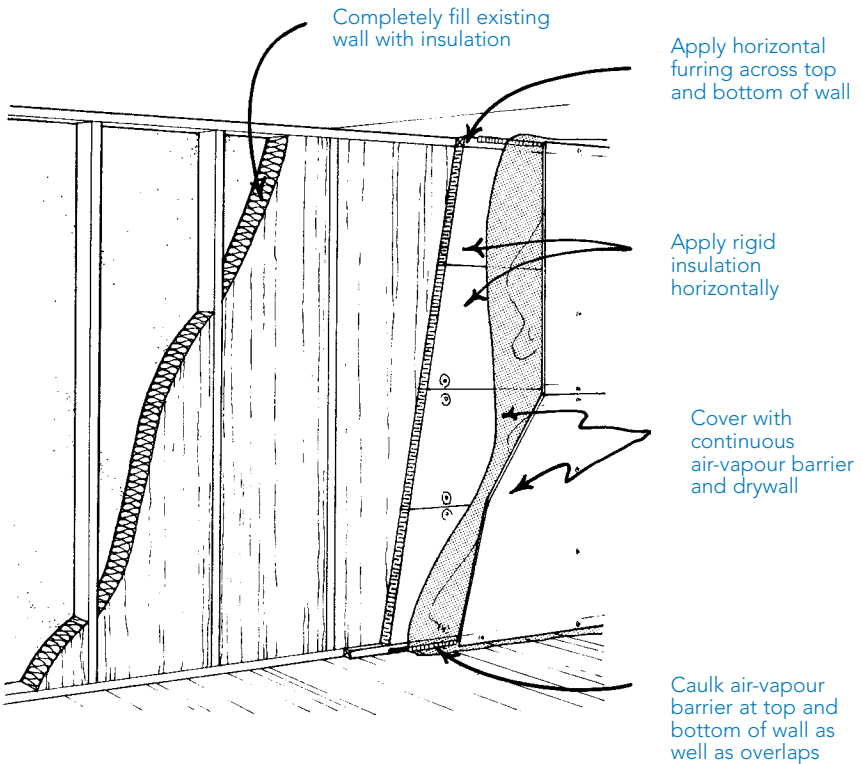

- Relocate any existing electrical boxes to the face of the furring (it may be easier to disconnect the existing boxes and install new ones).
- Insulate between the furring with 38mm (1½ in.) rigid insulation. Make sure the insulation extends behind any pipes, rather than in front, to prevent water from freezing and bursting the pipes.
- Cover the furring and insulation with a 0.15mm (6-mil) polyethylene air-vapour barrier. Seal the edges and overlaps of the air-vapour barrier with acoustical sealant
- Install 13mm (½ in.) drywall. Be careful not to puncture the air-vapour barrier when installing the drywall.

Figure 14

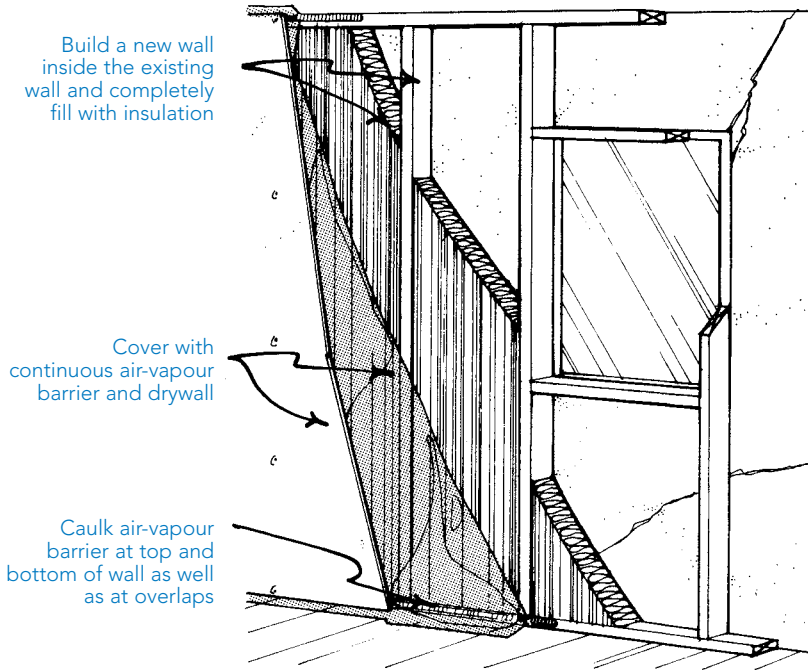

2. Build a new wall inside the old

- Remove the baseboards and trim around doors and windows.
- *If the existing wall has an air-vapour barrier, reduce its effectiveness by puncturing it 2 or 3 times in each stud space. This is necessary because the existing air-vapour barrier will now be on the cold side (in winter) of the new insulation.*
- Build a new 38 x 89mm (2 x 4 in.) wood frame wall inside the existing wall as shown in **Figure 14** (on page 19).
- Disconnect existing electrical boxes and install new boxes in the new frame wall.
- Insulate between the framing with RSI-2.1 (R-12) batt insulation. Extend the insulation behind any pipes rather than in front to prevent water from freezing and bursting the pipes.
- Cover the furring and insulation with a 0.15mm (6-mil) polyethylene air-vapour barrier. Seal the edges and overlaps of the air-vapour barrier with acoustical sealant.
- Install 13mm (1/2 in.) drywall. Be careful not to puncture the air-vapour barrier when installing the drywall.

Whether you rebuild the existing wall or build a new wall inside the old, the work can be staged on a room-by-room basis as time and money permit. Since the work is not affected by weather, it can be done at any time of year.

A factor to consider when insulating the walls from the inside is the loss of some living space.

Insulating From the Outside

If you plan to refinish the exterior of your home's walls, consider one of the following three options:

1. Install Rigid Insulation over the wall

- Attach 38mm (1 1/2 in.) rigid insulation directly over the existing wall finish as shown in **Figure 15**.
- Use special nails with large heads or washers to attach the insulation, rather than glue, to provide a more secure and permanent installation.
- Make sure there are no gaps or air pockets between the insulation and wall that could allow cold air to bypass the insulation. If the wall finish is rough or irregular, it is desirable to remove it and apply the insulation directly against the wall sheathing.

Figure 15

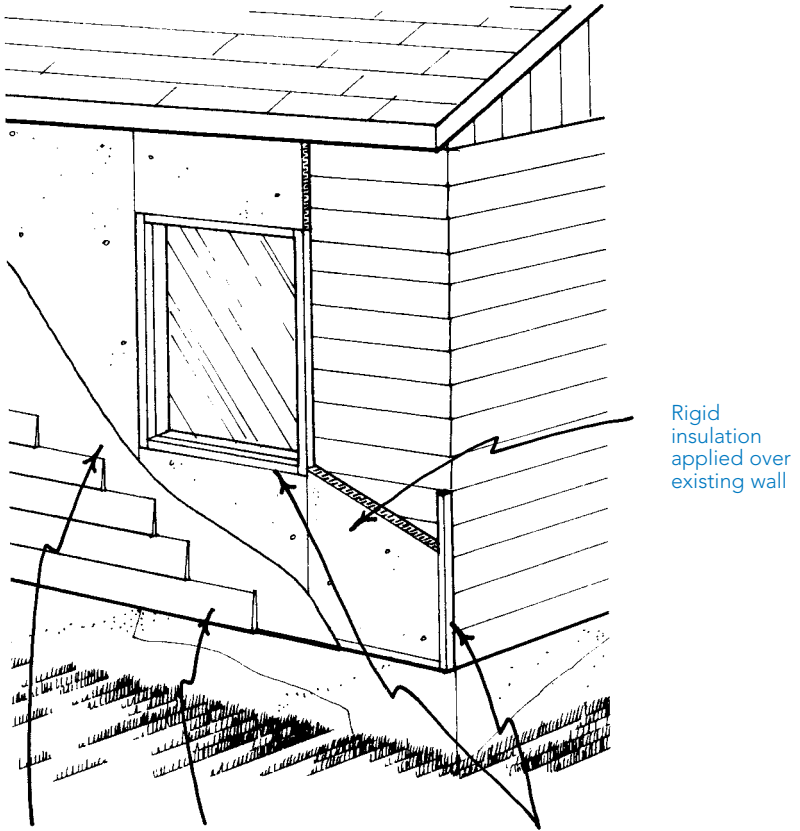

Building paper under new siding

New siding

Use wood framing along edges and around doors and windows

- Extend the insulation to the top of the wall. In some cases, this may require going up into the eaves (not a problem if you were planning to replace the soffits anyway).
- If the eaves do not extend far enough to prevent water from getting in between the insulation and the wall, add flashing at the top for this purpose. If you are going to have your roof reshingled anyway, consider extending the eaves at the same time.

- If the cost to relocate obstructions such as the electrical service, gas meter or steps is high, simply insulate around these obstacles rather than behind them.
- If the foundation walls are uninsulated, consider extending the rigid insulation down into the ground to cover them. Consult another publication in this series entitled *Basement and Crawlspace Insulation* (Booklet #2) for details.
- When covering the insulation with a new wall finish, make sure all door, window and other openings are properly flashed and caulked to prevent water penetration.

2. Build A new wall outside the old

- This technique, often referred to as “Double-Wall Retrofit” can accommodate high levels of insulation. Although it is the most costly and difficult method shown in this booklet, it has the greatest potential for reducing your home’s energy bills and improving its comfort.
- With this method, the existing walls are covered by a well-sealed, 0.15mm (6-mil) polyethylene air-vapour barrier. A new frame wall is then attached to the existing wall as shown in **Figure 16**.
- Ensure that the new frame wall is well-anchored to the existing structure. This is especially important if you intend to cover the wall with a heavy finish such as stucco.
- This new frame wall is then insulated with at least two layers of batt insulation. *It is important that this added insulation have at least twice the RSI (R) value of the existing wall assembly to prevent condensation from forming on the new air-vapour barrier in winter.*
For example, if the existing wall has an RSI value of 2.1 (R-12), the insulation being added must have an RSI value of at least 4.2 (R-24)
- This retrofit method results in a significant increase in the overall dimensions of the house. Before choosing this method, investigate whether there are municipal setback requirements from property lines (especially side yards) which limit the amount you can increase your wall thickness.

3. Install insulated siding

- Insulated siding is more expensive than siding with an ordinary backer board. It is a more convenient, but less effective, method of reducing heat loss than the previous two methods of applying insulation to the outside of a wall.

- When considering this option, remember that “empty” siding has an insulation value of RSI-0.13 (R-0.8) and that siding with standard 13mm backer board typically has a value of RSI-0.17 (R-1). The RSI-value of “insulation siding” can be as high as RSI-0.70 (R-4)
- To be effective, insulated siding should be installed so that cold, outdoor air cannot penetrate the joints in the siding and then flow between the insulated siding and the existing wall.

Figure 16

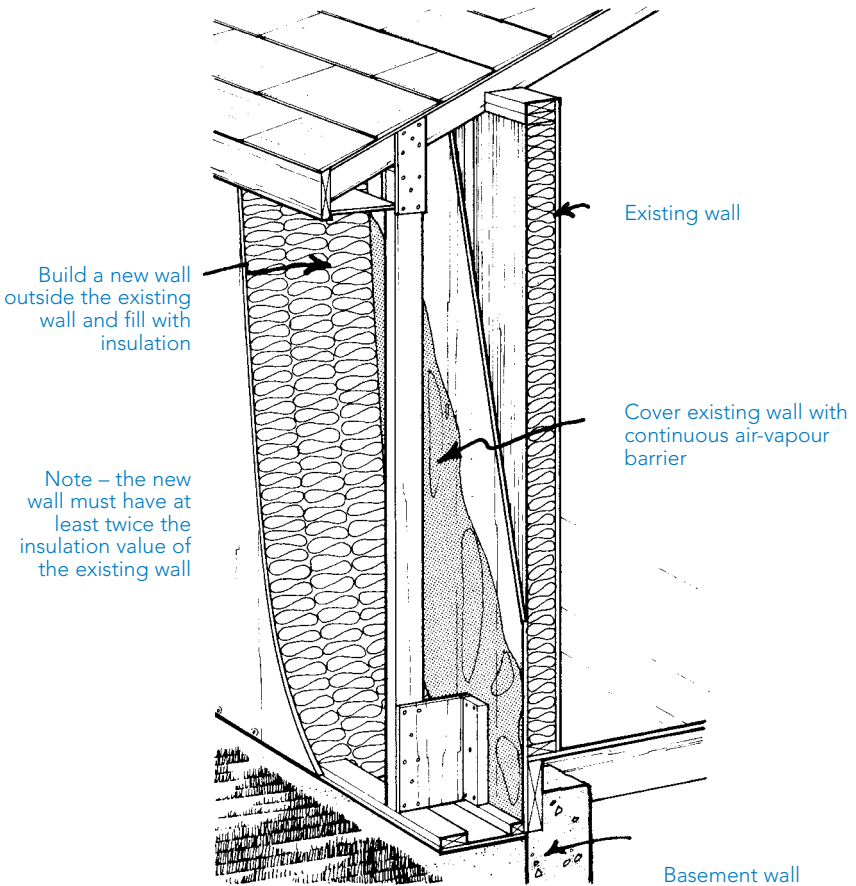

Table 1 — Insulation Summary

Material	RSI/100 mm	(R/in.)
Batt or Blanket Type Insulation		
<p>Glass Fibre</p> <ul style="list-style-type: none"> Composed of long fibres of spun glass loosely woven together and bonded with resin. Sizes available: <ul style="list-style-type: none"> Batt Length 1.22 m (4 ft.) Blanket Length up to 21.5 m (80 ft.) Width 381 or 400 mm (15 or 16 in.) 584 or 610 mm (23 or 24 in.) Thickness 76 to 304 mm (3 to 12 in.) 	2.2	(3.2)
Loose Fill Insulation		
<p>Cellulose Fibre</p> <ul style="list-style-type: none"> Manufactured from finely shredded newsprint with chemicals mixed in to resist fire and fungal growth. 	2.5	(3.6)
<p>Glass Fibre</p> <ul style="list-style-type: none"> Similar material to glass fibre batts but chopped up for blowing purposes. 	2.0	(2.9)
<p>Rock Wool</p> <ul style="list-style-type: none"> Made from natural rock which is melted, made into fibres and bonded. 	1.6	(2.3)

Advantages

- Easy to install in standard joist and stud spaces.
- Dries with little effect if exposed to moisture.
- Moderate cost.
- Some products are non-combustible; check with manufacturer.
- Lightweight.
- Non-settling.

Limitations

- Does not fit readily into uneven spaces.
- Can irritate the eyes, skin and respiratory system during installation.
- Little resistance to air leakage.

- Easily fills irregular spaces.
- Has a higher resistance to air leakage than most insulations.
- Is the only blown-in insulation that can be installed by a homeowner with rented equipment.
- Low cost.
- Recycles newspaper.

- Permanently damaged if exposed to excessive moisture.
- Should not be installed in contact with high-temperature sources (e.g. chimney, recessed lights, etc.)
- Should not be covered with heavier types of insulation which may compress it.
- Eye and respiratory system irritant during installation.
- May settle.

- Easily fills irregular spaces.
- Has a light weight for its RSI-value.
- Dries with little effect if exposed to moisture.
- Some products are non-combustible; check with manufacturer.
- Low cost.

- Can irritate the eyes, skin and respiratory system during installation.
- Little resistance to air leakage.
- May settle.

- Easily fills irregular spaces.
- Highly resistant to fire.
- Dries with little effect if exposed to moisture.
- Low cost.

- Skin irritant during application.
- Low RSI-value per unit thickness
- Little resistance to air leakage.
- May settle.

Material	RSI/100 mm	(R/in.)
Loose Fill Insulation (cont'd)		
Mineral Wool <ul style="list-style-type: none"> • Similar to rock wool except raw material is industrial slag. 	2.1	(3.0)
Vermiculite <ul style="list-style-type: none"> • Mica material that has been expanded by a high temperature steam process. 	1.6	(2.3)
Wood Shavings <ul style="list-style-type: none"> • By-product of wood industries, shavings are often mixed with lime and other chemicals. 	1.7	(2.5)

Rigid Board Insulation

Glass Fibre Board <ul style="list-style-type: none"> • Similar to glass fibre batts except formed into rigidboards. • Usually faced on one side with a material that is permeable to water vapour and impermeable to air movement. • Sizes available: <ul style="list-style-type: none"> Length 2.4 or 3 m (8 or 9 ft.) Width 1.2 m (4 in.) Thickness 25 to 28 mm (1 to 1¹/₂ in.) 	2.9	(4.2)
---	-----	-------

Advantages

- Same as rock wool.
- Easiest loose fill insulation to fill irregular spaces.
- Highly resistant to fire.
- Usually low cost if locally produced.
- Recycles wood waste.

Limitations

- Same as rock wool.
- High cost.
- Absorbs moisture and dries slowly.
- Low RSI-value per unit thickness
- May settle.
- Difficult to treat against fire, vermin and fungus growth.
- Absorbs moisture and dries slowly.
- Should not be installed in contact with high-temperature sources. (e.g. chimney, recessed lights, etc.)
- Low RSI-value per unit thickness
- May settle.

- Easy to handle and install.
- Some products are non-combustible; check with manufacturer.
- High RSI-value per unit thickness.

- High cost.
- More compressible than other rigid board insulations.
- Skin irritant during installation.
- Tedious to fit an irregular space.

Material	RSI/100 mm	(R/in.)
Rigid Board Insulation (cont'd)		
<p>Extruded Polystyrene</p> <ul style="list-style-type: none"> A foam plastic board composed of fine, closed cells containing a mixture of air and refrigerant gases (fluorocarbons). Sizes available: <ul style="list-style-type: none"> Length 1.2 or 2.4 m (4 or 8 ft.) Width 406 or 610 mm (16 or 24 in.) Thickness 25, 38, 51 or 78 mm (1, 1½, 2 or 3 in.) 	3.5	(5.0)
<p>Expanded Polystyrene (“Beadboard”)</p> <ul style="list-style-type: none"> Produced by a process that results in beads containing air, bonded together into rigid, foam plastic boards. Sizes available: <ul style="list-style-type: none"> Length 1.2, 2.4 or 2.7 m (4, 8 or 9 ft.) Width 406, 610 or 1220 mm (16, 24 or 48 in.) Thickness 19 to 152 mm (¾ to 6 in.) 		
<p>Polyurethane and Polyisocyanurate Boards</p> <ul style="list-style-type: none"> A foam plastic board with primarily closed cells filled with refrigerant gases (fluorocarbons). Usually foil-faced on both sides to strengthen the board and retain the gases which give it a high RSI-value Sizes available: <ul style="list-style-type: none"> Length 2.4 m (8 ft.) Width 1.2 m (4 ft.) Thickness 25, 38 or 51 mm (1, 1½ or 2 in.) 	4.2	(6.0)

Advantages

- Most moisture resistant rigid board insulation.
- Easy to handle and install.
- Can perform as an air-vapour barrier when installed on interior side of insulated cavities if joints are sealed properly.
- High RSI-value per unit thickness.

- Lowest cost per RSI-value of all the rigid insulation boards.
- Easy to handle and install.

- Highest RSI-value per unit thickness of all rigid insulation boards.
- Easy to handle and install.
- Can perform as an air-vapour barrier when installed on interior side of insulated cavities if joints are sealed properly.

Limitations

- High cost.
- Can be a fire hazard unless properly covered.
- Must be protected from exposure to sunlight or solvents.
- Tedious to fit in an irregular space.

- Can be a fire hazard unless properly covered.
- Must be protected from exposure to sunlight or solvents.
- Tedious to fit in an irregular space.

- Very high cost.
- Can be a fire hazard unless properly covered.
- Must be protected from exposure to sunlight or solvents.
- Loses some thermal resistance as it ages.
- Tedious to fit in an irregular space.

Metric Conversion Factors

A. Converting Imperial Units into Metric Units

Unit	Conversion	Multiply By
Thermal Resistance	R values to RSI values	0.1761
Length	inches to millimetres	25.40
	inches to centimetres	2.540
	feet to metres	0.3048
Area	square feet to square metres	0.09290
Volume	gallons to litres	4.546
	cubic feet to cubic metres	0.02832
Mass	pounds to kilograms	0.4536
Density	pounds/cubic feet to kilograms/cubic metre	16.02

B. Converting Metric Units into Imperial Units

Unit	Conversion	Multiply By
Thermal Resistance	RSI values to R values	5.678
Length	millimetres to inches	0.03937
	centimetres to inches	0.3937
	metres to feet	3.281
Area	square metres to square feet	10.76
Volume	litres to gallons	0.2200
	cubic metres to cubic feet	35.31
Mass	kilograms to pounds	2.205
Density	kilograms/cubic metre to pounds/cubic foot	0.06243

If you are uncertain of, or have any question or concern regarding, any subject matter herein or the safety and/or proper handling of any material(s) and/or product(s) that you may encounter in your undertaking, please consult resources such as Health Canada (Health Links) @ 1-888-315-9257, the Manitoba Department of Labour @ 1-800-282-8069, or CMHC (Canada Mortgage & Housing Corp.) @ 1-800-668-2642.

The information contained herein is published as a convenient reference for Manitoba Hydro's customers. While every effort has been made to provide accurate and complete information, Manitoba Hydro does not warrant the accuracy or efficacy thereof. Manitoba Hydro will not be liable for any loss, costs, damage or injury whatsoever, resulting from the use of this material.

Cette information est également disponible en français.

