

2024 Residential Wiring Guide

This guide is designed to help you install residential wiring safely and in accordance to the standards set by the Manitoba Electrical Code 2024.

Every effort has been made to ensure the accuracy of the information in this booklet. However, in the event of a discrepancy between this booklet and the governing Manitoba Electrical Code, the Manitoba Electrical Code shall take precedence.

Remember, the Manitoba Electrical Code is constantly being updated. Be sure to familiarize yourself with the latest code requirements before you begin wiring.

The Manitoba Electrical Code has been established to protect you and your family from shock and fire hazards that may occur when wiring is improperly done, or if sub-standard materials are used.

***Do it yourself* is a popular theme for home and cottage owners these days. However, electrical wiring must be safely and correctly installed in accordance with the Manitoba Electrical Code. You may be required to complete an electrical safety competency evaluation prior to being issued an electrical permit.**

Don't take shortcuts.

Violating the code puts lives at risk.

You can view or print a copy of this guide on our website at hydro.mb.ca.

Users of the Residential Wiring Guide (the "Guide") are responsible to ensure that their electrical wiring is installed in compliance with the current Manitoba Electrical Code and any other applicable laws, regulations, by-laws and codes. Users rely on the information contained in this Guide at their sole risk and are strongly encouraged to seek the advice of a qualified electrician regarding their electrical wiring installations. Manitoba Hydro shall not be liable for any injury, loss or damage caused to any person or property by reason of defects in any electrical wiring or in any improper installation of electrical wiring resulting from the use of this Guide.

Table of Contents

Chapter 1 - The Wiring Plan	4
General	5
Kitchen	5
Bathrooms and washrooms	7
Laundry areas	7
Garage/carport	7
Minimum 2 outdoor receptacles	7
Basement area	7
Other areas of the dwelling	7
Balcony or porch	7
Central vacuum system	7
Smoke alarms	8
Carbon monoxide alarms	8
Heat sensors in storage garages	8
Submersible pumps installed in lakes, rivers and streams	8
Service size	8
Obtaining an electrical permit	9
Special considerations	9
Chapter 2 - Materials	10
Explanation of materials and terms	10
Chapter 3 - Tools Required	13
Chapter 4 - Wiring	14
Chapter 5 - Circuits	17
Chapter 6 - Wiring Tips	20
Chapter 7 - Inspections	21
Chapter 8 - Wiring an Existing Building	22

Chapter 1 | The Wiring Plan

In this chapter, we'll detail what information should be marked on a floor plan to develop a wiring system, the size of service required, and how to obtain an electrical permit.

Figure 1 shows an example of a floor plan on which a wiring system has been developed.

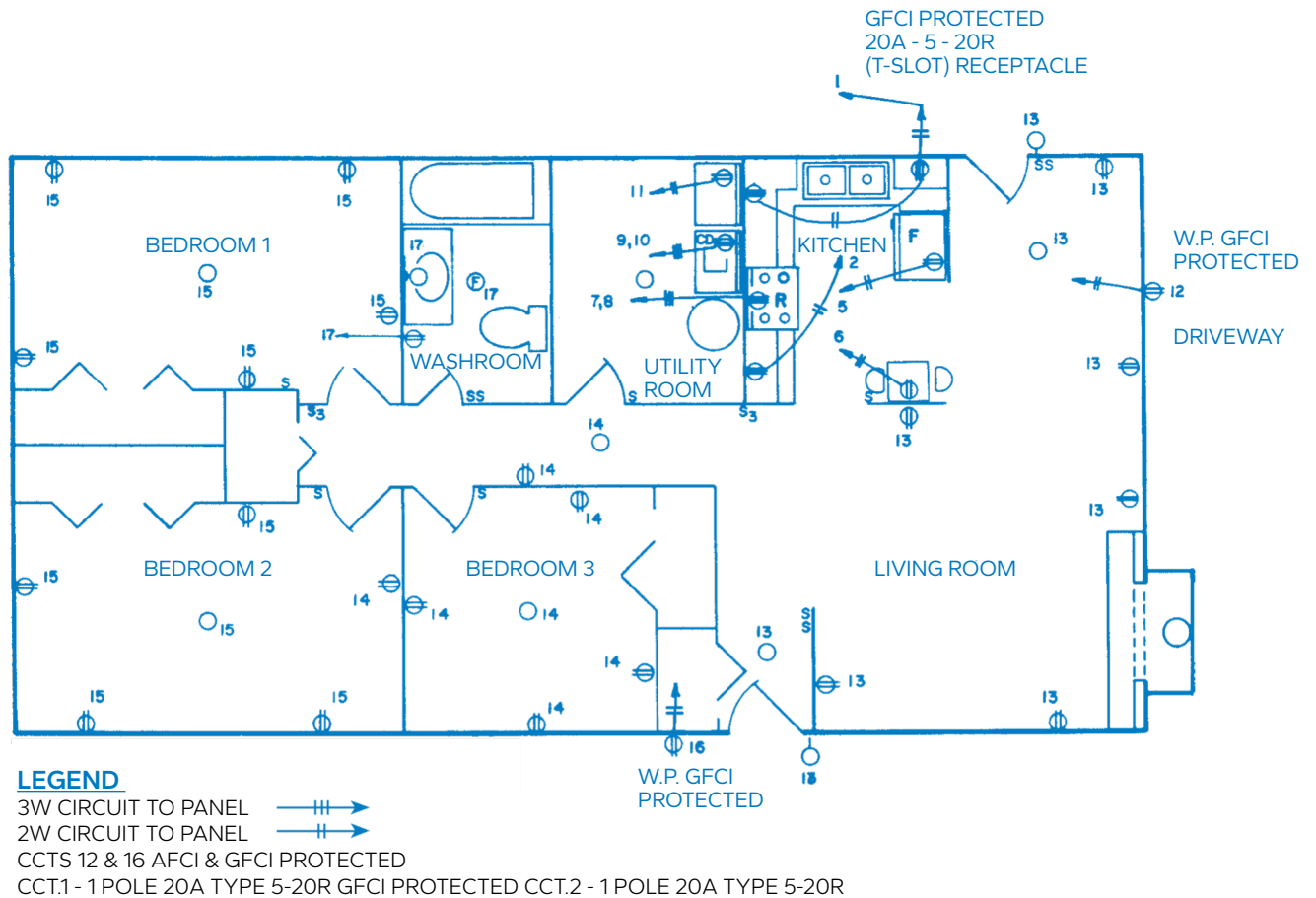

Figure 1 - Floor plan

General

- a) All 15-amp (5-15R) and 20-amp (5-20R) receptacles shall be tamper-resistant and shall be marked. Receptacles that are dedicated for stationary appliances where the receptacle is inaccessible or for those located 2 metres above the floor or finished grade are not required to be tamper resistant.
- b) Each branch circuit supplying 15-amp (5-15R) and 20-amp (5-20R) receptacles shall be protected by a combination-type Arc Fault Circuit Interrupter (CAFCI).

Receptacles installed for the kitchen fridge, kitchen counters, kitchen island, kitchen peninsula and those installed within one metre of the bathroom or washroom sink will be exempt from the CAFCI requirements. A single receptacle for a sump pump or sewage lift pump will also be CAFCI exempt when labelled to identify it as the sump pump or sewage pump receptacle.

In lieu of a CAFCI breaker, a CAFCI outlet branch circuit-type interrupter may be used when it is installed as the first outlet on the circuit and the wiring method from the overcurrent device to the first outlet is a metal raceway, armoured cable or non-metallic conduit or tubing.

Some circuits will require both CAFCI and Ground Fault Circuit Interrupter (GFCI) protection, like outdoor receptacle circuits, for example.

- c) A luminaire controlled by a wall switch shall be provided for each room.
- d) Each stairway with four or more risers must have a luminaire that is controlled by three-way wall switches located at the head and foot of the stairs. If the basement is not finished, then the luminaire is permitted to be controlled by a single switch located at the head of the stairs and provisions for three-way switching must be installed.
- e) There shall be no more than 12 outlets (lights and receptacles) on any two-wire branch circuit protected by a 15-amp breaker.

Kitchen

In the kitchen you'll require circuits and outlets for the refrigerator, range, counter space, built-in microwave oven, and lighting.

- f) **Refrigerator** – A separate receptacle, supplied from a separate circuit, for the exclusive use of the refrigerator must be installed. You may connect more than one kitchen refrigerator to this circuit.

Mark the location of the refrigerator receptacle on the floor plan and indicate that the circuit goes directly to the distribution panel.

- g) **Range** – A separate receptacle must be located in approximately the centre of the wall space where the range is located (130 mm maximum from the floor and oriented as shown in Figure 2).

Mark the location of the receptacle on the floor plan and indicate that the circuit goes directly to the distribution panel.

Where a gas (natural gas or propane) piping system or a natural gas connection outlet has been provided for a free-standing, all-natural gas range, one receptacle must be located behind the intended natural gas range location, not more than 130 mm from the floor and as mid-point as possible.

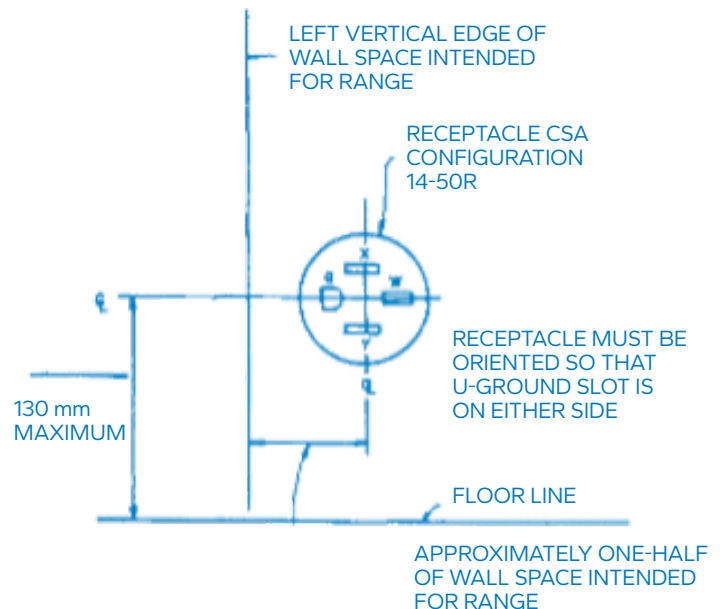

Figure 2 - Range receptacle installation

h) Usable counter space – At least two receptacles (15 A - CSA configuration 5-15R, or 20 A - CSA configuration 5-20R) shall be provided for kitchen counters. These receptacles must be installed so that no usable counter space, as measured along the wall line, is farther than 900 mm from a receptacle (excluding the area directly behind the kitchen sink).

If you are installing a peninsula or a fixed island in your kitchen you will have to install a receptacle for either or both of these areas if they have a continuous dimension greater than 300 x 600 mm. Receptacles located within 1.5 metres of the sink must be protected with a GFCI of the Class A type. This will require that they be of the 20 A, 5-20R type, connected to a 20 A circuit breaker or fuse and wired with No.12 AWG copper wire.

If more than two receptacles are required, they can be installed as either a three-wire 15 A circuit or two-wire 20 A circuit. This three-wire split receptacle circuit consists of a duplex receptacle wired in such a manner to provide 15 A of power from each outlet. No more than two receptacles, of either type, shall be permitted to be connected to any one circuit.

Mark the location of the receptacles and their circuitry on the floor plan. Indicate the two-wire or three-wire circuits going directly to the distribution panel (see Figure 3). A minimum of 2 circuits are required for the counter outlets.

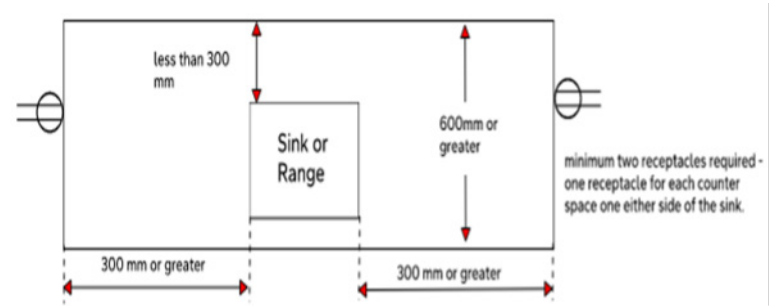
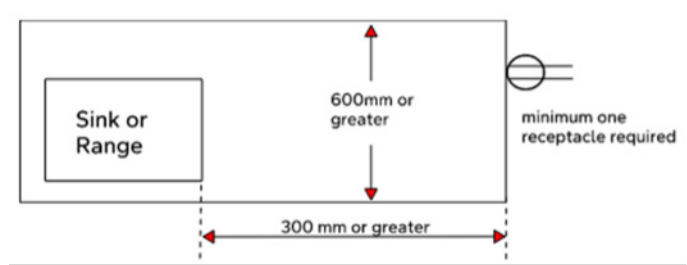
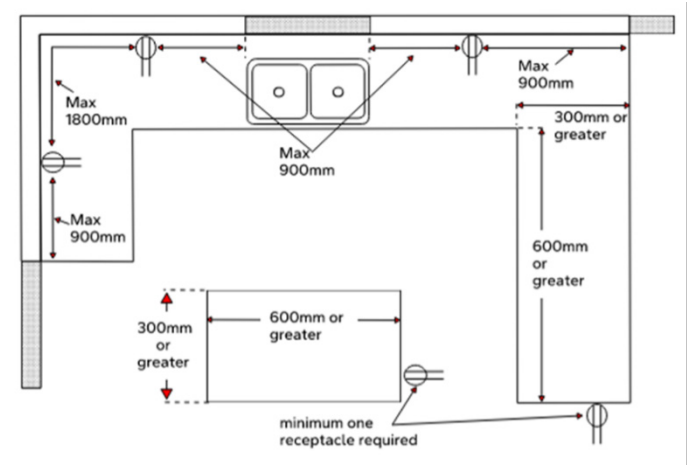

Figure 3 - Kitchen counter receptacle location requirements

i) Built-in microwave oven – If you plan to install a built-in microwave in an enclosure, a receptacle supplied from a separate circuit must be installed. This circuit must not be considered as forming part of other kitchen circuits. On the floor plan, mark the location of the receptacle and its circuit, and indicate that the circuit goes directly to the panel.

j) Cord-connected range hood or combination microwave oven/range hood unit – The receptacle required for this appliance is allowed to be installed in a cupboard or cabinet.

k) Additional outlets – Outlets for general lighting, task lighting, finished kitchen walls, and exhaust fans should be marked on the wiring plan. Their circuitry can be connected with the general circuitry in the structure.

Bathrooms and washrooms

A receptacle must be installed at each hand wash basin, and the receptacle must be protected by a GFCI. Mark the locations of all the bathroom outlets (lights, fans, and hand basin receptacles) on the floor plan.

Laundry areas

If you plan to include a laundry area in your home, you will require a receptacle served by a separate two-wire circuit for a washing machine and a separate receptacle supplied from a separate three-wire circuit for an electric dryer or in the case of a natural gas dryer, a separate, two-wire circuit. Mark the location of the receptacles on the floor plan and indicate the circuits going directly to the distribution panel.

Garage/carport

At least one duplex receptacle is required for each vehicle space in a garage or carport. Receptacles are also required within one metre of each cord-connected garage door opener. A dedicated circuit is required for a garage or carport. The garage lighting may be added to this circuit.

Minimum 2 outdoor receptacles

You must have at least one receptacle installed for the driveway area along with an additional outlet accessible from grade level on the opposite outside wall of a cottage or home for use with appliances designed to be used outdoors. These 2 receptacles are required to be connected to their own separate branch circuit.

All outdoor receptacles located within 2.5 metres of ground or grade level must be protected by a GFCI and CAFCI.

All installed 15- and 20-amp receptacles exposed to the weather will require coverplates marked "Extra Duty".

Mark the location of each receptacle on the floor plan and indicate that the circuit goes directly to the distribution panel.

Basement area

Also see page 11.

Even if you do not plan to finish your basement at this time, you must install at least one receptacle in the basement area. This receptacle may be on a circuit that supplies other general use receptacles.

Other areas of the dwelling

General use receptacles in bedrooms, living rooms, and other areas must be located every 1.8 metres. When measuring the spacing between receptacles, do not include:

- doorways;
- areas occupied by a fully opened door;
- windows that extend to the floor;
- fireplaces;
- other permanent installations that limit the use of the wall space.

No point in a hallway of a home or cottage is to be farther than 4.5 metres from a receptacle, without going through a doorway. For example, an outlet in a bedroom cannot be counted as a hallway receptacle.

All general use outlets must be shown on the plan and the circuitry should be marked to indicate that no more than 12 outlets are connected to one two-wire circuit.

Balcony or porch

In an area such as a balcony or porch, you must install at least one receptacle.

Central vacuum system

If you plan to install a central vacuum system, it must be supplied by a receptacle on a separate circuit.

Smoke alarms

Smoke alarms with battery backup must be installed on all floors, including basements. If the home is a split-level or a bi-level and it is 900 mm above or below the adjacent level, it must be counted as a different floor and must have its own alarm. A smoke alarm with battery backup must be installed in each bedroom and there must be one in the hallway that serves the bedroom(s).

They must operate at 120 volts and be supplied by an unswitched lighting branch circuit or a combination lighting and receptacle branch circuit.

Smoke alarms shall be interconnected so that the operation of any one device will activate all the other alarms. Combination smoke and carbon monoxide alarms may be used as they can reduce the number of units to be maintained.

NOTE: Smoke alarms must be installed according to the manufacturer's instructions.

Carbon monoxide alarms

A carbon monoxide alarm is required in every home that contains a fuel-burning appliance or an attached garage. Alarms are to be installed either inside each bedroom or, if outside, within 5 metres of each bedroom door.

They must operate at 120 volts and be supplied by an unswitched lighting branch circuit or a combination lighting and receptacle branch circuit.

Carbon monoxide alarms shall be interconnected so that the operation of any one device will activate all the other alarms. Combination smoke and carbon monoxide alarms may be used as they can reduce the number of units to be maintained.

NOTE: Carbon monoxide alarms are to be installed according to the manufacturer's instructions.

Heat sensors in storage garages

A fixed-temperature heat sensor shall be installed in an attached garage and is to be installed on the ceiling of the garage or bottom of a ceiling joist of garages with no ceiling. Permanent wiring to an electrical circuit not protected by a CAFCI or GFCI must ensure that activation of the sensor will cause all smoke alarms within the home to sound.

Submersible pumps installed in lakes, rivers and streams

If you plan to install a submersible pump in a lake, river or stream, the voltage supplying the pump must not exceed 150 volts to ground. The branch circuit that supplies the submersible pump must be provided with GFI protection with a high enough setting to allow normal operation of the pump but must limit the ground fault current to less than 10 mA for a period not exceeding 2.7 seconds.

Only heat trace cable having a metal braid or sheath is allowed to be installed on water lines to prevent freezing. This metal braid or sheath must be bonded to ground.

The heat trace circuit must be protected by a GFI with a high enough setting to allow the normal operation of the heater.

The setting for this GFI is from 25 mA to 30 mA. The GFI required for both of these types of installations is different from the normal GFCI for your bathroom or outside receptacles, which has a setting of between 4 mA to 6 mA.

Service size

Manitoba Hydro recommends a minimum service size of 100 amps, complete with a 24-circuit distribution panel. A 100-amp service should be capable of supplying up to 10 kW of electric heating, in addition to the normal loads in a residence or summer cottage.

If you are installing more than 10 kW of electric heating, a service larger than 100 amps is required. The service size should be based on calculated kilowatt demand, which takes into consideration the floor area, appliances, electric heating, pumps, motors, and other loads that may be installed, such as hot tubs and saunas.

An electrical service permit can only be issued to a licensed electrician, and the service must be installed by the electrician. Consult with your electrician to ensure the service size is appropriate for your current and future needs.

A load calculation must be submitted by a licensed electrician with the permit application for any Level 2 EVSE (electric vehicle supply equipment).

Obtaining an electrical permit

As mentioned in the introduction, you must obtain an electrical permit before starting any wiring.

You must apply online for an electrical permit at hydro.mb.ca.

Manitoba Hydro will review your application, calculate fees and issue an electrical permit. The fees are assessed in accordance with the current Manitoba Hydro schedule of electrical permit fees.

If you plan to build a new structure, your electrician must contact your local Manitoba Hydro Customer Service Centre to determine where the electrical service will be attached to the building (see “Service conduit” Chapter IV).

Special considerations

“Finished walls” refers to any wall covered with a permanent finish such as drywall or paneling extending to within 450 mm of the floor. For basement foundations constructed with ICF materials, receptacles must be installed at the correct spacing prior to the required drywall covering for exposed ICF construction.

Combination type AFCI protection (CAFCI) is required for all receptacle branch circuits other than the refrigerator, kitchen counter, bathroom vanity and sump pump receptacles. Microwave oven receptacles, outdoor receptacles located on dwellings, washing machine and HRV receptacles all require CAFCI protection.

One or more receptacles added to existing branch circuits also require CAFCI protection. This can be achieved by using outlet type CAFCI protection for those specific outlets.



Chapter 2 | Materials

The Manitoba Electrical Code requires that all wiring materials be approved by an accredited certification organization, such as those below. Failure to use approved materials will result in the inspector refusing to accept the installation. Manitoba Hydro will not connect the service until the inspector accepts the installation.

Electrical inspection authorities across Canada will accept electrical equipment with certification markings other than the CSA logo. Here are some logos that denote approved electrical and gas equipment:



1. **Canadian Standards Association**



2. **Underwriters Laboratories Inc.**

The UL logo without the small "c" is not acceptable for use in Manitoba.



3. **Warnock Hersey**



4. **Electrical Testing Laboratory**

The ETL logo without the small "c" is not acceptable for use in Manitoba.



5. **Canadian Gas Association**



6. **Underwriters Laboratories Canada Inc.**

For further information, contact your local electrical inspection authority or the Office of the Fire Commissioner, Inspection and Technical Services Manitoba.

Explanation of materials and terms

American Wire Gauge Number:

The standard measurement for the diameter of a wire is the American Wire Gauge (AWG) number. It is a measurement of the wire only, and does not include the insulation covering the wire.

Single conductors:

Single conductors must be covered by insulation, except when the conductor is for a service neutral or for grounding purposes, in which case it may be bare. Single conductor cables are normally installed in service raceways.

Multi-conductor cables:

Multi-conductor cables are cables consisting of two or more conductors. There are two types of non-metallic (NM) sheath cable commonly used for wiring a home or cottage. The first is NMD90, which is used indoors for the bulk of your circuit wiring. The second is NMWU, which is used outdoors and may be buried in the ground. NM cable is identified by the size and number of conductors it contains. For example, a cable with two No. 14 AWG conductors (one white and one black), and a bare bonding conductor, is called "14/2 with bond."

Common wire sizes:

There are four basic wire sizes that are commonly used for wiring the circuits of a home or cottage: No. 14, No. 12, No. 10, and No. 8.

- **No. 14 AWG** is used for 15-amp circuits that supply loads such as receptacles, switches, and lights.
- **No. 12 AWG** is used for 20-amp circuits that supply loads such as kitchen counter receptacles.
- **No. 10 AWG** is used for 30-amp circuits that supply loads such as electric clothes dryers.
- **No. 8 AWG** is used for 40-amp circuits that supply loads such as electric ranges.

The size of the conductor for each circuit is determined by the amperage required for the particular circuit.

Electrical boxes:

The most commonly used electrical boxes for residential and cottage wiring projects are octagonal, square, and device types. There are various sizes of boxes. The size you use depends on the number and size of conductors, number of wire connectors used, and whether or not a device such as a receptacle or switch will be mounted in the box. When cables are installed in electrical boxes, care must be taken to ensure the proper size of box is used.

The most common size of octagonal box used for residential wiring is 4 x 1.5 inches. You may install ten No. 14 AWG insulated conductors or eight No. 12 AWG insulated conductors in this size of box.

If you need to install more conductors, then use a deeper box or employ an extension ring. The two most common sizes of device boxes are 3 x 2 x 2.5 inches and 3 x 2 x 3 inches. Where switches or receptacles are to be installed in these boxes, the maximum number of insulated conductors that may be installed are:

- **3x2x2.5 inches**
 - › five – No. 14 AWG insulated conductors, or
 - › four – No. 12 AWG insulated conductors
- **3x2x3 inches**
 - › seven – No. 14 AWG insulated conductors, or
 - › five – No. 12 AWG insulated conductors
 - › A 4 11/16 inch square box is required for dryer and range receptacles.



REMOVE ONE SIDE FROM EACH BOX



GANG SECTIONAL BOXES TOGETHER TO FORM LARGER BOXES



OCTAGONAL OUTLET OR JUNCTION BOX



BLANK COVER



LAMPHOLDER COVER

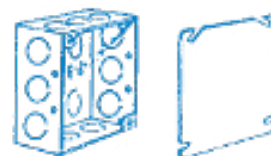

SQUARE JUNCTION BOX AND COVER

Figure 4 - illustrates the various types of boxes most commonly used in residential and cottage wiring.

Switches:

There are four common types of switches:

- **A single-pole switch** controls a light or receptacle from one location only.
- **A three-way switch** has three terminals and operates in conjunction with another three-way switch to control a receptacle or light from two locations.
- **A four-way switch** has four terminals and is used in conjunction with two three-way switches to control a light or receptacle from more than two locations.
- **A dimmer switch** allows you to turn an incandescent light on or off, and vary the brightness of the light according to your needs.



SINGLE-POLE SWITCH

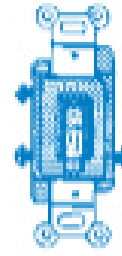

THREE-WAY SWITCH

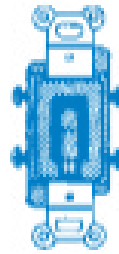

FOUR-WAY SWITCH



DIMMER SWITCH

Receptacles:

There are several grades of receptacles available. Receptacles in areas such as the kitchen or driveway and those used for heavy loads should be of top quality, as they will be used constantly.

Figure 5 - Common Switch Types of Switches



SINGLE-POLE SWITCH

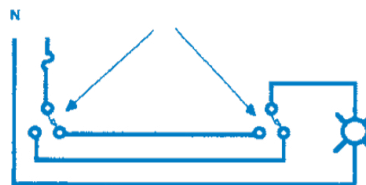

THREE-WAY SWITCH

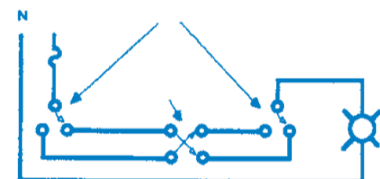

FOUR-WAY SWITCH

Figure 5.1 - Examples of single-pole, 3-way, and 4-way switching

Chapter 3 | Tools Required

The following are some of the tools required to install electric wiring.

(You may already have many of them.)

- **Screwdrivers:**

- › No. 8 Robertson
- › No. 6 Robertson
- › Standard Flat blade

- **Pliers:**

- › lineman's pliers
- › multi-purpose diagonal cutters
- › needle nose pliers

- **Miscellaneous:**

- › Allen key
- › cable stripper
- › hammer
- › knife
- › power drill
- › voltage tester
- › wood drill bits

Equipment safety

1. Always keep your power tools cleaned and lubricated, according to the manufacturer's instructions in the operating manual.
2. Check power cords and extension cords frequently. If the insulation is broken or the power cord is frayed, replace it immediately. Do not try to fix it.
3. Always disconnect equipment by removing the plug from the electrical outlet first. Then disconnect the cord from the power tool.
4. Never operate power equipment while standing on wet ground or in water.
5. When you have finished using your power tools, store them in a clean, dry place. Don't leave them lying around unprotected.
6. Be careful with extension cords. Run them along walls if possible, so that no one will step on them or trip over them. Never set a heavy object on an extension cord.



Chapter 4 | Wiring

For new builds, once you have gathered the required tools and materials and obtained your electrical permit, you will need to arrange for electricity at your construction site. You may wish to have power at your construction site to operate your power tools. There are several ways to do this:

- Have an electrician obtain a permit and install a temporary builder's electrical service on the site. For a nonrefundable installation fee, Manitoba Hydro will connect it.
- Borrow power from a neighbour, using a three-wire outdoor cord of a sufficient size to prevent excessive voltage drop due to the length of the cord.
- Have an electrician install your permanent building service (on a separate electrical permit) and one convenience outlet in your home or cottage. Manitoba Hydro will connect the service prior to the installation of rough-in wiring provided the building is secure and weatherproof.

Service includes a service entrance head, service conduit, service mast (if required), meter socket, main service box, distribution panel and a grounding electrode.

Special requirements for buildings in a flood hazard zone.

Buildings located within a flood hazard zone as identified by the Province of Manitoba require special provisions. The service box must be located above the designated flood level for that property and any below grade electrical circuits require ground fault protection. This includes sump and sewage lift pumps. Please see the Manitoba Electrical Code Technical Interpretations for more information.

Flooded buildings which are still energized present a severe life safety hazard. This not only relates to electrical shock but electrical equipment and wiring which has been submerged or otherwise subjected to excessive moisture may present a fire hazard when re-energized.

Please see the Manitoba Hydro Informative Bulletin regarding Flooded and Water Damaged Buildings for more information on the proper cleanup and restoration methods.

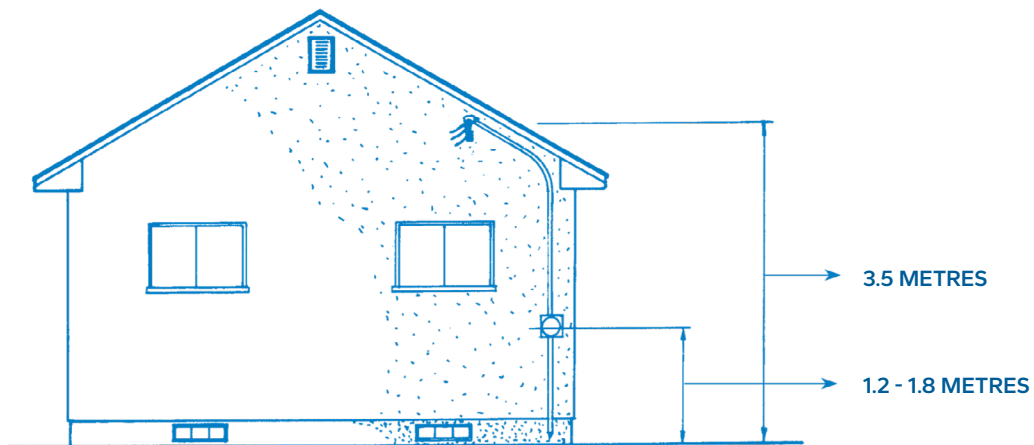

Figure 6 – Typical service conduit installation

Service conduit

Service entrance equipment must be installed by an electrician. Before your electrician installs the service entrance equipment they should obtain their own electrical permit and contact a local Manitoba Hydro Customer Service Centre to find out where the service will be attached to the building.

It's your responsibility to clear any brush and trees between your building and the hydro pole.

The service conduit protects the service conductors between the service entrance head and the main service box. These are the conductors that Manitoba Hydro will connect to on the outside of your building. The size of the service conductors depends on the size of service required.

If the structure is tall enough, the service entrance head and conduit can be mounted on the wall, without the use of a service mast (Figure 6).

If the building is so low that proper clearances cannot be met with the service entrance head mounted on the wall, a service mast kit will have to be installed by an electrician.

The following are some of the measurements which must be observed (Figure 7):

- When Manitoba Hydro's service conductors run across a landscaped yard or across a finished grade to your building, a minimum clearance of 3.5 metres is required.
- When Manitoba Hydro's service conductors run across a driveway to your building, a minimum clearance of 4 metres is required.
- When Manitoba Hydro's service conductors run across highways, streets, and alleys to your building, a minimum clearance of 5.5 metres is required.

Meter sockets

The meter socket must be installed by an electrician and installed at a distance of not less than 1.2 metres and not more than 1.8 metres from the finished grade or deck. The type of meter socket to be installed generally depends on the location of the service box (see Figure 6).

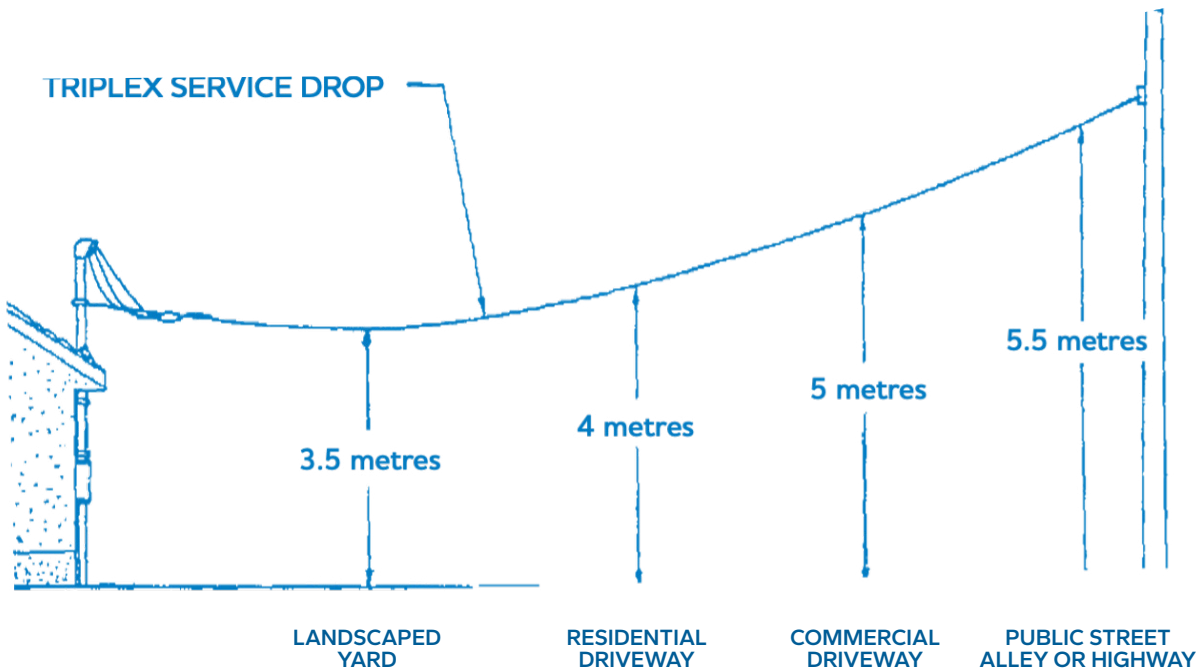

Figure 7 - Minimum clearance requirements

Service box and distribution panel

The service box and distribution panel must be installed by an electrician. The service box and distribution panel contain the main disconnect and fuse or main circuit breaker, the fuses or circuit breakers which protect each individual circuit in the building, and the grounding connection for the system. They make up the main electrical control centre for home or cottage wiring.

The service conductors from the load side of the meter socket are connected to the line side terminals inside the service box.

The distribution panel may be part of the main service box or may be a separate panel. However, when the distribution panel and the main service box are combined, it is called a combination panel.

Examples of circuits and their uses are:

- **120 volts** – lights and convenience outlets;
- **120/240 volts** – range, dryer, etc.;
- **240 volts** – baseboard heaters, electric water heaters, and central air conditioners rated at 240 volts.

The service box and distribution panel are located on the inside of the building. However, they must not be located in closets, bathrooms, or other similarly undesirable places. The distribution panel must be located as high as possible above the finished floor, with the overcurrent device operating handles no more than 1.7 metres above the finished floor. It is recommended that a 3/4-inch-thick piece of plywood of sufficient size be used for mounting the panel

Service grounding

All service grounding must be installed by an electrician. Service entrance metal parts, including conduit, meter fittings, and boxes must be grounded in accordance with the Manitoba Electrical Code.

The grounding conductor connects the neutral bus bar in the service box to the grounding electrode.

The grounding electrode may be a metallic public water system, in which case the grounding conductor would connect to the street side of the water meter.

When there is no public water system, e.g. at a cottage location, an artificial grounding electrode must be used, such as two approved copper-clad ground rods (at least 3 metres x 15.8 mm) spaced 3 metres apart. When unable to drive the ground rod into the earth below ground level near the structure, select an area where the ground rod can be driven easily. The bare grounding conductor must be connected to the ground rod by an approved clamp. The top of the rod should be below grade.

An alternative artificial grounding electrode is a ground plate or plate electrode. A plate electrode must have a surface area of not less than 0.2 square metres, not less than 6 mm thick if made from iron or steel, and not less than 1.5 mm thick if made from non-ferrous metal. It must also be buried at least 600 mm below finished grade.



Chapter 5 | Circuits

The two bus bars in the distribution centre allow you to divide the current into smaller units for feeding the branch circuits, using a circuit breaker or a fuse for each circuit.

A 120-volt circuit consists of one live conductor and one neutral conductor. Each 120/240-volt circuit consists of two live conductors and one neutral conductor. Each 240-volt circuit consists of two live conductors.

Running cables

When wiring the circuits of a home or cottage, you must run NM sheathed cable through the studs and joists. Where the cable runs between boxes and fittings, it must be supported by straps or other devices. Cables that are run through holes in joists or studs are considered supported.

Cables should not run on or across:

- a) the upper face of ceiling joists or the lower face of rafters in attic or roof spaces where the vertical distance between the joists and the rafters exceeds 1 metre;
- b) the lower face of basement joists, unless suitably protected from mechanical injury.

Cables may be run across the upper side of ceiling rafters where the vertical distance between the joists and rafter is less than 1 metre.

Drill the correct size hole for the cable; holes should be large enough that the cable is not pinched, but not so large as to weaken the member. If the cable runs less than 32 mm from the face of the stud, you must install an approved protector plate on the face of the stud to protect the cable.

Cable must be supported every 1.5 metres as well as within 300 mm of the boxes as illustrated in Figure 8. The cable must be secured to the box.

This can be accomplished in several ways: using boxes with built-in cable clamps (Figure 10) or by using cable connectors (Figure 11). Distribution panels are not equipped with built-in cable clamps, so cable connectors must be used.

Remove the outer jacket of the cable. Leave 150 mm of conductor in the box to attach to the device being installed.

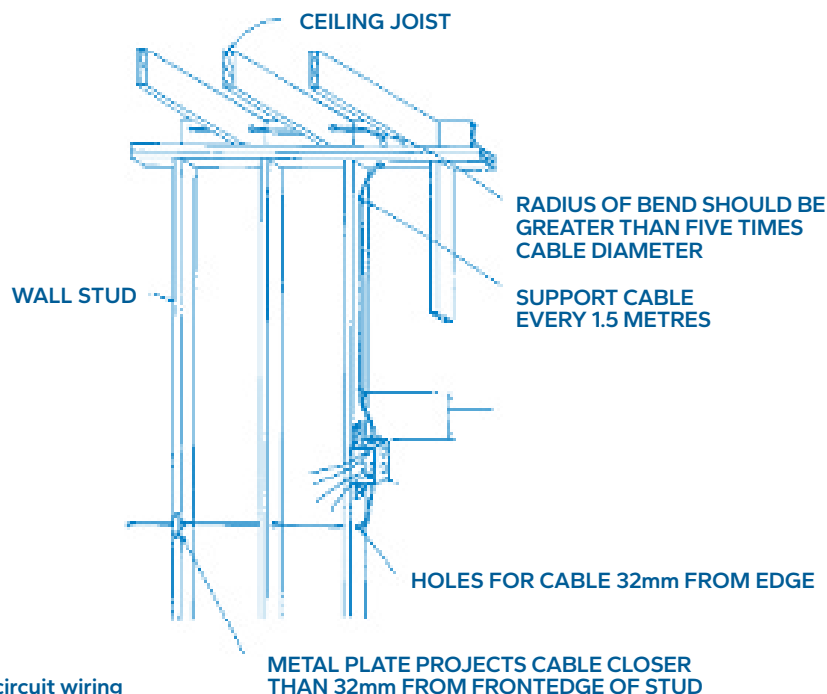

Figure 8 – Typical branch circuit wiring

Mounting boxes

Boxes must be properly supported as shown in Figure 9. Single boxes that will be used for duplex receptacles or switches are generally fastened to the studs, using wood screws.

However, when ganged sectional boxes are used, you will have to provide additional support with cross members which are fastened between the studs (Figure 9). The support may consist of a board, which is wide enough to cover the entire back of the box, two wooden strips, or manufactured box supports which are obtainable from your electrical supplier.

When boxes having any dimension greater than 100 mm are used, they must also be secured on at least two sides, e.g. dryer and range outlets and three gang one-piece boxes.

The Manitoba Electrical Code requires that the vapour barrier be maintained around boxes which are installed on outside walls and insulated ceilings.

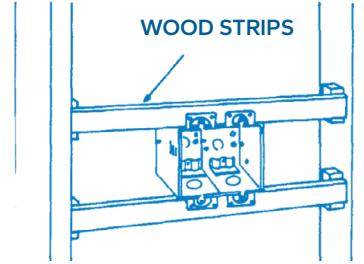

Figure 9 - Outlet box supports

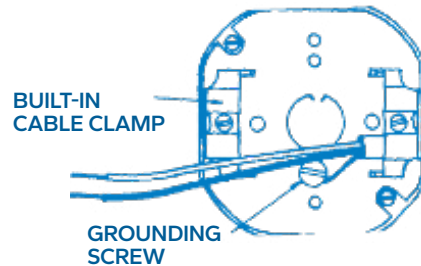

Figure 10 - Outlet box with built-in cable clamps

Receptacles

Receptacles have three different coloured screw terminals:

- Brass-coloured screws for live conductors;
- White- or silver-coloured screws for neutral conductors;
- Green-coloured screws for the circuit bonding conductor (Figure 12).

When you connect a duplex receptacle, connect the live conductor (black or red) to one of the brass-coloured screws.

Since the brass-coloured screws are connected to a conductive tab on duplex receptacles, there's no need to connect both terminals. The same applies for the white- or silver-coloured screws for the neutral conductor. Only one white- or silver-coloured screw is necessary to connect the white neutral conductor.

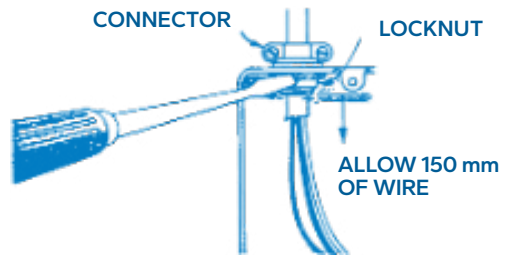

Figure 11 - Outlet box supports receptacles

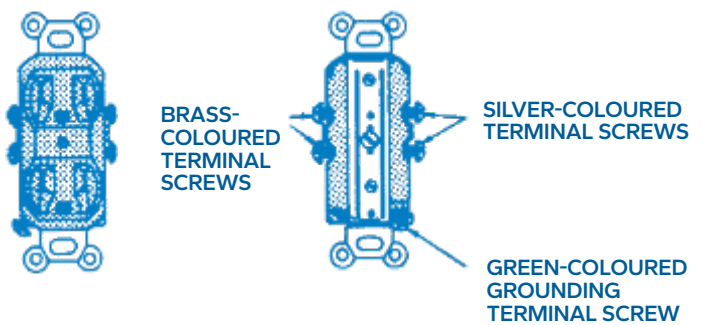

Figure 12 - Identification of terminal screws on receptacles

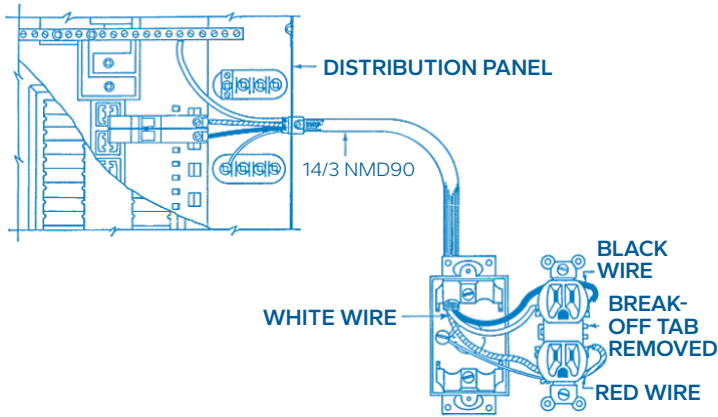

Figure 13 - Split receptacle installation

In some instances, you'll have to connect split receptacles. To do this, use three-conductor NM type cables instead of two-conductor. Use a duplex receptacle for the split receptacle, but on the side where the live conductors are connected, remove the break-off tab. Then connect the black conductor to one of the brass-coloured terminals and the red conductor to the other brass-coloured terminal. Connect the white conductor to the silver-coloured screw (Figure 13).

Remember that both the metal box and the receptacle must be bonded. To do this, loop the bare bonding conductor under one of the two bonding screws in the box, and then connect it to the green-coloured screw on the receptacle (Figure 14).

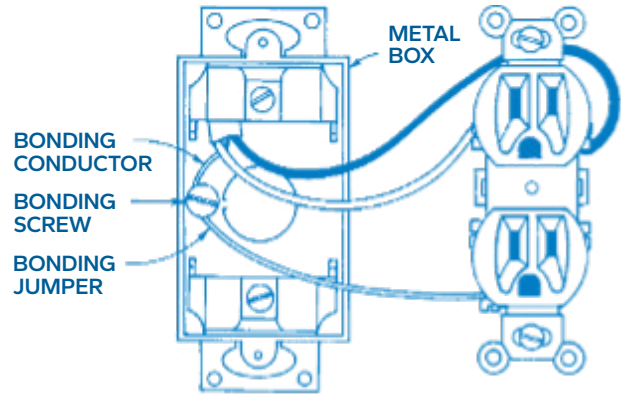

Figure 14 – Receptacle bonding conductor connections

Colour coding of conductors

Usually, conductors that are black, red, or any colour other than white or green are considered live. White denotes the neutral conductor and green denotes the bonding conductor.

When a switch loop (Figure 15) is installed, the white conductor or neutral must be carried to the switch, and the black conductor or red conductor must be used as the switch return.

A three-wire cable must therefore be used.

- When feeding 240-volt equipment, such as electric baseboard heaters or water heaters, the white conductor may be used as a live conductor, provided it is marked by painting or taping.

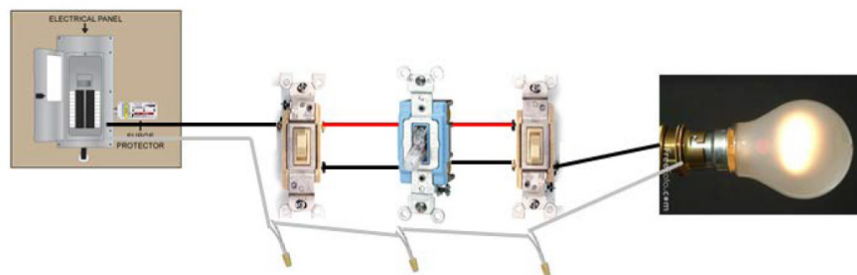

Figure 15 – Switch-loop colour coding

Important change for 2024 Manitoba Electrical Code

An identified conductor or neutral must be installed at every point of control such as a switch box. This may require that a 14/3 NM cable be run to each switch box. An example is shown above. A three conductor cable (black, red, white) may be required.

Chapter 6 | Wiring Tips

Attaching conductors to screw type terminals

Strip 13 mm to 19 mm of insulation from the wire. Then, using needle nose pliers, form a three-quarter loop in the uncovered conductor. Hook the conductor clockwise around the screw so that as you tighten the screw, the loop of wire will close and form a tight connection.

Make sure the insulation on the conductor does not extend under the screw as this will make a poor connection.



Cable Stacker

Use cable stacker fasteners to center multiple cables on the stud face 32 mm from the edge.

Use of wire connectors

The most common method of connecting conductors is to use a wire connector. The recommended practice for making this connection is as follows:

1. Remove the insulation to expose the ends of the conductor in accordance with the manufacturer's instructions.
2. Hold stripped ends together, with ends of the wire even.
3. Push connector firmly against the wire ends and twist on the connector.

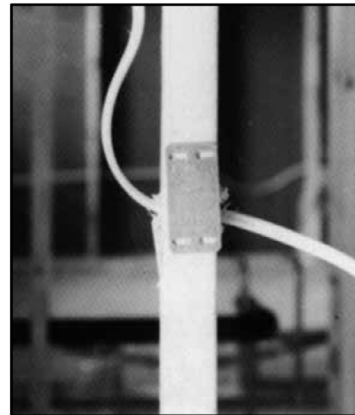

Metal Protectors

Use approved metal plates in situations where the cable is too close to the front of the studs or joists.

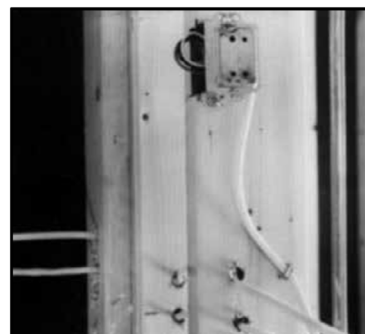

Supporting Cables

When running cables through joists and studs, be sure to drill the holes large enough so the cables are not pinched or crushed.

Chapter 7 | Inspections

When your work is completed at certain stages, the wiring will need to be checked by the electrical inspector.

Permit fees normally cover only the rough-in inspection and final inspection. If extra inspections are required to facilitate construction schedules or remedy defects identified by an inspector, additional inspection fees will apply.

Rough-in inspection

This inspection is made before the wiring is covered by insulation, a vapour barrier, or wallboard.

Before calling an electrical inspector for the rough-in inspection, the following work must be completed:

- The wiring for all lights, switches and receptacles must be installed in the walls, secured to the structural members, and terminated in the outlet boxes.
- All the connections, joints and bonding in the outlet boxes must be completed. Only the conductors required for the connection of the light fixtures, receptacles or switches should be left unconnected.

Final inspection

The electrical installation must be complete. The light fixtures, receptacles and switches must be installed and connected. The electrical circuits in the panel must be clearly identified as well. Finally, the cover plates for receptacles and switches must be installed.



Chapter 8 | Wiring an Existing Building

Whether you plan to build an addition, add a room to a home or cottage, or finish a recreational room, the same basic principles of wiring and guidelines apply. You must obtain an electrical permit and the installation must meet the requirements of the current Manitoba Electrical Code.

Service size

Make sure your existing service will be large enough to handle the additional load. If you are uncertain, consult with an electrician to see if the existing service is adequate.

In order to accommodate additional circuits, you may have to have an electrician install a larger panel or an additional panel. The new panel must be installed according to the latest Code requirements regarding location, ampacity, and the number of circuit positions.

Existing electrical services

Existing electrical services should be maintained in good condition. Cracked or damaged service conductors should be replaced. Panel directories should be updated whenever branch circuits are added. Panel fillers and knockout seals should be provided to seal any openings.

Clearance of overhead service conductors must be maintained and if reduced by decks, pools or hot tubs, a service mast or other modifications may be required.

Electrical services that have been disconnected for more than 6 months will require a safety inspection prior to reconnection.

Upgrading existing branch circuits

When you plan to connect new wiring to existing branch circuits, remember that both the old and new wiring must comply with the latest Code standards. This applies to dwellings as well as attached and detached garages and outbuildings.

For instance, if the existing cable is damaged, it must be replaced with new cable.

If there are extension cords in your home that are used on a permanent basis to connect a freezer, washing machine, lamp, or a television set, you must install additional electrical outlets. It is hazardous to use extension cords as permanent wiring.

Appliances such as a freezer or washing machine should be on separate circuits. An outlet for a television set and similar equipment may be connected to an existing circuit, as long as it will not overload that circuit.

Make sure that all the cables are properly supported and that any broken switch face plates or outlet face plates are replaced. Receptacles in the kitchen, bathroom, and laundry room must also be properly bonded.

Any new branch circuits must comply with the current addition of the Manitoba Electrical Code with respect to Combination Arc Fault Circuit Interrupters (CAFCI), tamper proof receptacles, and GFCI protection. Please see the Manitoba Electrical Code Technical Interpretations for more information.

Safety

The Manitoba Electrical Code exists to ensure the safe installation and operation of wiring systems. The Code applies to both new and existing structures.

Keep these safety rules in mind when you work on existing wiring:

- Ensure that cables and equipment are de-energized before you start any work. You must either turn off the circuit breaker for the circuit you're working on; remove the fuse for the circuit; or turn off the main switch. Never work with live conductors.
- Before you begin to work on a circuit, test to ensure it has been turned off.
- If you have to increase the service size, consult an electrician and have Manitoba Hydro disconnect the service at the entrance. Do not disconnect the service yourself, and never make the changeover while the lines are energized.
- Do not proceed until you know how to complete the job properly and safely.